



# Owner's Manual and Instructions

## GUARDIAN® Agricultural Animal Confinement Building Heater



MODELS	OUTPUT (Btuh)	FUEL
AB250	250,000	Available in either L.P. Gas Vapor Withdrawal or Natural Gas Configurations.

### Certification by:



\* Specific models are certified by C.S.A. International. Contact L.B. White co. for further information.

## Congratulations!

**You have purchased the finest agricultural building heater available.**

Your new L.B. White heater incorporates the benefits from the most experienced manufacturer of heating products using state-of-the-art technology.

We, at L.B. White, **thank you** for your confidence in our products and welcome any suggestions or comments you may have...call us, toll-free, at 1-800-345-7200.

### ATTENTION ALL USERS

This heater has been tested and evaluated by C.S.A. International in accordance with ANSI/IAS U.S. LC2-1996 as well as the Canadian Gas Association Standard for Gas Fired Brooders, CAN1-2.20-M85 and is listed and approved as a direct gas-fired circulating heater for the heating of agricultural animal confinement buildings. If you are considering using this product for any application other than its intended use, then please contact your fuel gas supplier, or the L.B. White Co., Inc.



Quality heaters you can count on.

W6636 L.B. White Rd., Onalaska, WI 54650 ■ (800) 345-7200 ■ (608) 783-5691 ■ (608) 783-6115, fax ■ info@lbwhite.com

150-24206

 **GENERAL HAZARD WARNING**

- Failure to comply with the precautions and instructions provided with this heater, can result in:
  - Death
  - Serious bodily injury or burns
  - Property damage or loss from fire or explosion
  - Asphyxiation due to lack of adequate air supply or carbon monoxide poisoning
  - Electrical shock
- Read this Owner's Manual before installing or using this product.
- Only properly-trained service people should repair or install this heater.
- Save this Owner's Manual for future use and reference.
- Owner's Manuals and replacement labels are available at no charge. For assistance, contact L.B. White at 800-345-7200.

 **WARNING**

- Proper gas supply pressure must be provided to the inlet of the heater.
- Refer to rating plate for proper gas supply pressure.
- Gas pressure in excess of the maximum inlet pressure specified at the heater inlet can cause fires or explosions.
- Fires or explosions can lead to serious injury, death, building damage or loss of livestock.
- Gas pressure below the minimum inlet pressure specified at the heater inlet may cause improper combustion.
- Improper combustion can lead to asphyxiation or carbon monoxide poisoning and therefore serious injury or death to humans and livestock.

 **WARNING**  
**Fire and Explosion Hazard**

- Not for home or recreational vehicle use.
- Installation of this heater in a home or recreational vehicle may result in a fire or explosion.
- Fire or explosions can cause property damage or loss of life.

 **WARNING**  
**Fire and Explosion Hazard**

- Keep solid combustibles a safe distance away from the heater.
- Solid combustibles include wood or paper products, feathers, straw, and dust.
- Do not use the heater in spaces which contain or may contain volatile or airborne combustibles.
- Volatile or airborne combustibles include gasoline, solvents, paint thinner, dust particles or unknown chemicals.
- Failure to follow these instructions may result in a fire or explosion.
- Fire or explosions can lead to property damage, personal injury or loss of life.

**CONSIGNES DE SECURITE**

Il est interdit d'utiliser des liquides inflammables ou dégageant des vapeurs inflammables, à proximité de tout appareil fonctionnant au gaz.

**CONSIGNES DE SECURITE**

Si vous sentez une odeur de gaz:

1. Ouvrez les fenêtres.
2. Ne touchez pas aux interrupteurs électriques.
3. Éteignez toute flamme nue.
4. Contactez immédiatement votre compagnie de gaz.

**FOR YOUR SAFETY**

Do not store or use gasoline or other flammable vapors and liquids in the vicinity of this or any other appliance.

**FOR YOUR SAFETY**

If you smell gas:

1. Open windows.
2. Don't touch electrical switches.
3. Extinguish any open flame.
4. Immediately call your gas supplier.



# Table of Contents

<u>SECTION</u>	<u>PAGE</u>
General Information .....	3
Heater Specifications .....	4
Safety Precautions .....	5
Installation Instructions	
General .....	7
Air Diverter Installation Instructions .....	8
Hanging Installation Instructions .....	9
Sediment Trap Assembly Instructions .....	9
Thermostat Installation Instructions .....	10
Manual Shut-Off Valve, Hose and Regulator Assembly Instructions .....	10
Start-Up Instructions .....	11
Shut-Down Instructions .....	11
Variable Heat Output Instructions .....	12
Cleaning Instructions .....	13
Maintenance Instructions .....	13
Electrical Connection and Ladder Diagram .....	14
Heater Component Function .....	15
Parts Identification	
Parts Schematic .....	16
Parts List .....	17
Warranty Policy .....	18
Replacement Parts and Service .....	18

## General Information

This Owner’s Manual includes all options and accessories commonly used on this heater. However, depending on the configuration purchased, some options and accessories may not be included.

When calling for technical service assistance, or for other specific information, always have model number, configuration number and serial number available. This information is contained on the dataplate.

This manual will instruct you in the operation and care of your unit. Have your qualified installer review this manual with you so that you fully understand the heater and how it functions.

The gas supply line installation, installation of the heater, and repair and servicing of the heater requires continuing expert training and knowledge of gas heaters and should not be attempted by anyone who is not so qualified. See page 6 for definition of the necessary qualifications. A detailed Installation and Service Guide is available, at no charge, to qualified personnel by contacting the local L.B. White distributor, dealer or the L.B. White Company.

Contact your local L.B. White distributor or the L.B. White Co., Inc. for assistance, or if you have any questions about the use of the equipment or its application.

The L.B. White Co., Inc. has a policy of continuous product improvement. It reserves the right to change specifications and design without notice.

# Heater Specifications

## Model

AB250

### SPECIFICATIONS

		L.P. Gas	Natural Gas
Maximum Input (BTUH)		250,000	
Minimum Input (BTUH)		160,000	
Ventilation Air Required to Support Combustion		1,050 CFM	
Inlet Gas Supply Pressure Acceptable at the Inlet of the Heater for Purpose of Input Adjustment	<b>MAX.</b>	13.5 in. W.C.	
	<b>MIN.</b>	11.5 in. W.C.	7 in. W.C.
Burner Manifold Pressure		10 in. W.C.	4 in. W.C.
Fuel Consumption Per Hour	<b>MAX.</b>	11.57 lbs.	250 cu. ft.
	<b>MIN.</b>	7.41 lbs.	160 cu. ft.
Motor Characteristics		Ball Bearing 1/3 H.P. 1100 RPM	
Electrical Supply (Volts/Hz/Phase)		115/60/1	
Amp Draw (Starting Amps Includes Igniter)	<b>STARTING</b>	7.3	
	<b>CONTINUOUS OPERATION</b>	4.5	
Dimensions (Inches) L x W x H		30 3/4 x 18 1/4 x 28 1/4	
Minimum Safe Distances From Nearest Combustible Materials	<b>TOP</b>	1 ft.	
	<b>SIDES</b>	1 ft.	
	<b>BACK</b>	1 ft.	
	<b>BLOWER OUTLET</b>	6 ft.	
	<b>GAS SUPPLY</b>	L.P. Gas Supply – 6 ft. (1.83 m) Natural Gas Supply – N/A	
Net Weight (lbs.)		114	
Shipping Weight (lbs.)		125	

 **WARNING**  
**Asphyxiation Hazard**

- Do not use this heater for heating human living quarters.
- Do not use in unventilated areas.
- The flow of combustion and ventilation air must not be obstructed.
- Proper ventilation air must be provided to support the combustion air requirements of the heater being used.
- Refer to the specification section of the heater's Owner's Manual, heater dataplate, or contact the L.B. White Company to determine combustion air ventilation requirements of the heater.
- Lack of proper ventilation air will lead to improper combustion.
- Improper combustion can lead to carbon monoxide poisoning in humans leading to serious injury or death. Symptoms of carbon monoxide poisoning can include headaches, dizziness and difficulty in breathing.
- Symptoms of improper combustion affecting livestock can be disease, lower feed conversion, or death.

## FUEL GAS ODOR

LP gas and natural gas have man-made odorants added specifically for detection of fuel gas leaks.

If a gas leak occurs, you should be able to smell the fuel gas.

**THAT'S YOUR SIGNAL TO GO INTO IMMEDIATE ACTION!**

- Do not take any action that could ignite the fuel gas. Do not operate any electrical switches. Do not pull any power supply or extension cords. Do not light matches or any other source of flame. Do not use your telephone.
- Get everyone out of the building and away from the area immediately.
- Close all propane (LP) gas tank or cylinder fuel supply valves, or the main fuel supply valve located at the meter if you use natural gas.
- Propane (LP) gas is heavier than air and may settle in low areas. When you have reason to suspect a propane leak, keep out of all low areas.
- Natural gas is lighter than air and can collect around rafters or ceilings.
- Use your neighbor's phone and call your fuel gas supplier and your fire department. Do not re-enter the building or area.
- Stay out of the building and away from the area until declared safe by the firefighters and your fuel gas supplier.
- **FINALLY**, let the fuel gas service person and the firefighters check for escaped gas. Have them air out the building and area before you return. Properly trained service people must repair the leak, check for further leakages, and then relight the appliance for you.

## ODOR FADING -- NO ODOR DETECTED

- Some people cannot smell well. Some people cannot smell the odor of the man-made chemical added to propane (LP) or natural gas. You must determine if you can smell the odorant in these fuel gases.
- Learn to recognize the odor of propane (LP) gas and natural gas. Local propane (LP) gas dealers and your local natural gas supplier (utility) will be more than happy to give you a "scratch and sniff" pamphlet. Use it to become familiar with the fuel gas odor.
- Smoking can decrease your ability to smell. Being around an odor for a period of time can affect your sensitivity to that particular odor. Odors present in animal confinement buildings can mask fuel gas odor.
- The odorant in propane (LP) gas and natural gas is colorless and the intensity of its odor can fade under some circumstances.
- If there is an underground leak, the movement of gas through the soil can filter the odorant.
- Propane (LP) gas odor may differ in intensity at different levels. Since propane (LP) gas is heavier than air, there may be more odor at lower levels.
- **Always be sensitive to the slightest gas odor.** If you continue to detect any gas odor, no matter how small, treat it as a serious leak. Immediately go into action as discussed previously.

## ATTENTION -- CRITICAL POINTS TO REMEMBER!

- Propane (LP) gas and natural gas have a distinctive odor. Learn to recognize these odors. (Reference "Fuel Gas Odor" and "Odor Fading" sections above.)
- If you have not been properly trained in repair and service of propane (LP) gas and natural gas fueled heaters, then do not attempt to light heater, perform service or repairs, or make any adjustments to the heater on propane (LP) gas or natural gas fuel system.
- Even if you are not properly trained in the service and repair of the heater, ALWAYS be consciously aware of the odors of propane (LP) gas and natural gas.
- A periodic "sniff test" around the heater or at the heater's joints; i.e. hose, connections, etc., is a good safety practice under any conditions. If you smell even a small amount of gas, CONTACT YOUR FUEL GAS SUPPLIER IMMEDIATELY. DO NOT WAIT!

1. Do not attempt to install, repair, or service this heater or the gas supply line unless you have continuing expert training and knowledge of gas heaters.

Qualifications for service and installation of this equipment are as follows:

- a. To be a qualified gas heater service person, you must have sufficient training and experience to handle all aspects of gas-fired heater installation, service and repair. This includes the task of installation, troubleshooting, replacement of defective parts and testing of the heater. You must be able to place the heater into a continuing safe and normal operating condition. You must completely familiarize yourself with each model heater by reading and complying with the safety instructions, labels, Owner's Manual, etc., that is provided with each heater.
  - b. To be a qualified gas installation person, you must have sufficient training and experience to handle all aspects of installing, repairing and altering gas lines, including selecting and installing the proper equipment, and selecting proper pipe and tank size to be used. This must be done in accordance with all local, state and national codes as well as the manufacturer's requirements.
2. All installations and applications of L.B. White heaters must meet all relevant local, state and national codes. Included are L.P. gas, natural gas, electrical, and safety codes. Your local fuel gas supplier, a local licensed electrician, the local fire department or similar government agencies, or your insurance agent can help you determine code requirements.
    - a. For U.S.A. installations and applications:
      - ANSI/NFPA 58, latest edition, Standard for Storage and Handling of Liquefied Petroleum Gas and/or
      - ANSI Z223.1/NFPA 54, National Fuel Gas Code
      - ANSI/NFPA 70, National Electrical Code.
    - b. For Canadian Installations and Applications:
      - CAN1-B149.1 or CAN1-B149.2 Installation Codes
      - CSA C22.1 Part 1 Standard Canadian Electrical Code. CSA C22.2 No. 3, Electrical Features of Fuel-Burning Equipment.
  3. Do not move, handle, or service heater while in operation or connected to a power or fuel supply.
  4. This heater may be installed in areas subject to washdown. This heater may only be washed on the external case assembly—see Cleaning Instructions. Do not wash the interior of the heater. Use only compressed air, soft brush or dry cloth to clean the

interior of the heater and it's components. After external washdown, do not operate this heater until it is completely dry. In any event, do not operate the heater for at least one hour after external washdown.

5. For safety, this heater is equipped with a manual reset high-limit switch and an air proving switch. Never operate this heater with any safety device that has been bypassed. Do not operate this heater unless all of these features are fully functioning.
6. Do not operate the heater with its door open or panel removed.
7. Do not locate fuel gas containers or fuel supply hoses anywhere near the blower outlet of the heater.
8. Do not block air intakes or discharge outlets of the appliance. Doing so may cause improper combustion or damage to heater components leading to property damage or animal loss.
9. The hose assembly (if provided) shall be visually inspected on an annual basis. If it is evident there is excessive abrasion or wear, or if the hose is cut, it must be replaced prior to the heater being put into operation. The hose assembly shall be protected from animals, building materials, and contact with hot surfaces during use. The hose assembly shall be that specified by the manufacturer. See parts list.
10. Check for gas leaks and proper function upon heater installation, before building repopulation or when relocating.
11. This heater should be inspected for proper operation by a qualified service person before building repopulation and at least annually.
12. Always turn off the gas supply to the appliance if the appliance is not going to be used in the heating of livestock.
13. This heater is equipped with a three-prong (grounding) plug for your protection against shock hazard and must be plugged directly into a properly grounded three-prong receptacle. Failure to use a properly grounded receptacle can result in electrical shock, personal injury, or death.
14. In a hanging type installation, rigid pipe or copper tubing coupled directly to the heater may cause gas leaks during movement, and therefore must not be used. Use only gas hose assemblies that are rated and approved for L.P.gas and natural gas in a hanging type of installation.
15. Installations not using the gas hose supplied with this appliance must connect dimensionally using American National Standard Wrought Steel and Wrought Iron Pipe B36/10-1970. (Aluminum piping or tubing shall not be used.) Copper tubing when used for conveying natural gas, shall be internally tinned or equivalently treated to resist sulphur.



### **WARNING**

**Fire or explosion hazard.**

**Can cause property damage, severe injury or death.**

1. Disconnect power supply before wiring to prevent electrical shock or equipment damage.
2. To avoid dangerous accumulation of fuel gas, turn off gas supply at the heater's service valve before starting installation, and perform gas leak test after completion of installation.
3. Do not force the gas control knob. Use only your hand to turn the gas control knob. Never use any tools. If the knob will not operate by hand, the control should be replaced by a qualified service technician. Force or attempted repair may result in fire or explosion.

1. Read all safety precautions and follow L. B. White recommendations when installing this heater. If during the installation or relocating of heater, you suspect that a part is damaged or defective, call a qualified service agency for repair or replacement.
2. Make sure the heater is properly positioned before use and is hung level. Observe and obey all minimum safe distances of the heater to the nearest combustible materials. Minimum safe distances are given on the heater nameplate and on page 4 of this manual.
3. The heater is approved for indoor use only.
4. The unit's gas regulator (with pressure relief valve) should be installed outside of building. Any regulators inside the buildings must be properly vented to the outside. Local, state and national codes always apply to regulator installation. Natural gas regulators with vent limiting device may be mounted indoors without venting to outdoors.
5. Ensure that all accessories that ship within the heater have been removed from inside of heater and installed. This pertains to air diverters, hose, regulators, etc.
6. Ensure that a sediment trap is installed at the gas valve inlet to prevent foreign materials (pipe compound, pipe chips and scale) from entering the gas valve. Debris blown into the gas valve may cause that valve to malfunction resulting in a serious gas leak that could result in a possible fire or explosion causing loss of products, building or even life. A properly installed sediment trap will keep foreign materials from entering the gas valve and protect the safe functioning of that important safety component.
7. Any heater connected to a piping system must have an accessible, approved manual shut off valve installed within six feet (6 ft.) of the heater.

8. Check all connections for gas leaks using approved gas leak detectors. Gas leak testing is performed as follows:
  - Check all pipe connections, hose connections, fittings and adapters upstream of the gas control with approved gas leak detectors.
  - In the event a gas leak is detected, check the components involved for cleanliness and proper application of pipe compound before further tightening.
  - Furthermore tighten the gas connections as necessary to stop the leak.
  - After all connections are checked and any leaks are stopped, turn on the main burner.
  - Stand clear while the main burner ignites to prevent injury caused from hidden leaks that could cause flashback.
  - With the main burner in operation, check all connections, hose connections, fittings and joints as well as the gas control valve inlet and outlet connections with approved gas leak detectors.
  - If a leak is detected, check the components involved for cleanliness in the thread areas and proper application of pipe compound before further tightening.
  - Tighten the gas connection as necessary to stop the leak.
  - If necessary, replace the parts or components involved if the leak cannot be stopped.
  - Ensure all gas leaks have been identified and repaired before proceeding.



### **WARNING**

**Fire and Explosion Hazard**

- Do not use open flame (matches, torches, candles, etc.) in checking for gas leaks.
- Use only approved leak detectors.
- Failure to follow this warning can lead to fires or explosions.
- Fires or explosions can lead to property damage, personal injury or loss of life.

9. A qualified service agency must check for proper operating gas pressure upon installation of the heater.
10. Light according to instructions on heater or within owner's manual.
11. It is extremely important to use the proper size and type of gas supply line to assure proper functioning of the heater. Contact your fuel gas supplier for proper line sizing and installation.

12. Ensure the heater has the proper gas regulator for the application. A regulator must be connected to the gas supply so that gas pressure at the inlet to the gas valve is regulated within the range specified on the dataplate at all times. Contact your gas supplier, or the L.B. White Co., Inc. if you have any questions.
13. This heater can be configured for use with either L.P. gas vapor withdrawal or natural gas. Consult the dataplate, located on interior of the burner end or motor end door, for the gas configuration of the specific heater. Do not use the heater in an L.P. gas liquid withdrawal system or application. If you are in doubt, contact the L.B. White Co., Inc.
14. Eventually, like all electrical/mechanical devices, the thermostat can fail. Thermostat failure may result in either an underheating or overheating condition which

may damage critical products and/or cause animal injury or death. Critical products and/or animals should be protected by a separate back-up control system that limits high and low temperatures and also activates appropriate alarms.

15. Take time to understand how to operate and maintain the heater by using this Owner's Manual. Make sure you know how to shut off the gas supply to the building and also to the individual heater. Contact your fuel gas supplier if you have any questions.
16. Any defects found in performing any of the service or maintenance procedures must be eliminated and defective parts replaced immediately. The heater must be retested by properly qualified service personnel before placing the heater back into use.

## AIR DIVERTER INSTALLATION INSTRUCTIONS

(Model AB250 Optional Accessory)

1. Optional air diverters can be installed in the heater outlet to provide direction to the heated air as it exits the heater. Installation options include installing the diverters in such a way as to broadly distribute the air in two 45 degree paths or to focus the air flow in one 45 degree direction. See Fig. 1.
2. The air diverters may require hand forming prior to installation. Make 90 degree bends utilizing the perforations provided. Diverters should have the shape as shown in Fig. 1.
3. The air diverter's tabs on each half will "pop" into the blower outlet between the inside of the case assembly and the blower housing outlet. If the notched tabs do not "pop" into the blower outlet, loosen (do not remove) the blower outlet screws. Doing this provides a gap into which you can insert the tabs. Retighten the screws after installation.

**FIG. 1** (Typical installation allowing two directions of air movement.)

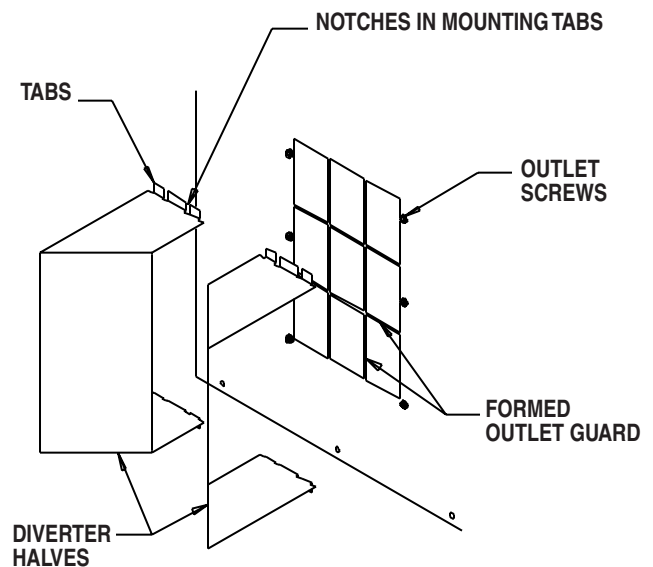

Alternate Air Diverter Installations



1. Assemble according to the illustration and tighten all eyebolts securely. (See Fig. 2):

**FIG. 2**

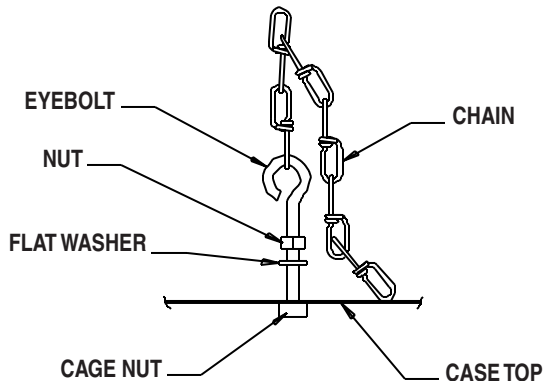

2. Be sure heater is securely fastened and is hanging level. (Check crosswise and lengthwise.)
3. See Fig. 3 for **typical** indoor installation. In any animal confinement building, consideration must be given to making sure the heater is located away from the livestock so that livestock cannot knock the heater, tear it loose from its mounting, or damage the heater or its gas supply line in any way. Make sure you observe and obey minimum clearance distances to combustible materials as stated in the specification section of this owner's manual and on the heater itself.

**FIG. 3**

NOTE: REGULATORS SHOULD ALWAYS BE MOUNTED OUTDOORS. IF CIRCUMSTANCES FORCE INSTALLING THE REGULATOR INDOORS, THE REGULATOR'S VENT MUST BE VENTED OUTDOORS USING VENT LINE NO SMALLER THAN VENT OPENING.

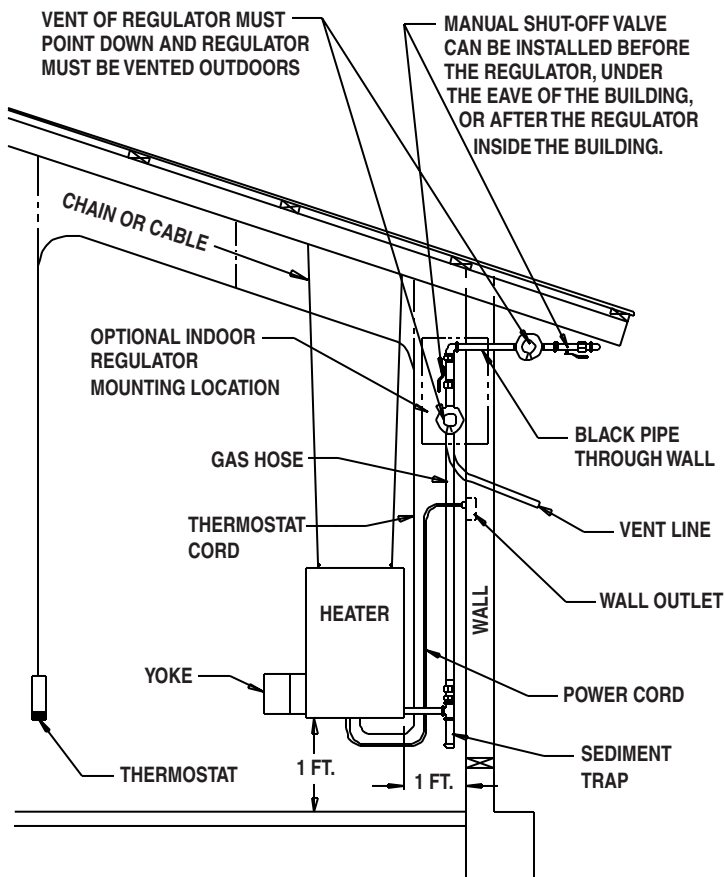

## SEDIMENT TRAP ASSEMBLY

Assemble the tee, nipples and cap together and tighten securely. See Fig. 4. The sediment trap assembly must always be mounted in a vertical position. Make sure pipe thread compound that is resistant to both L.P. gas and natural gas is used in making all connections. **Check all connections for gas leaks using approved gas leak detectors.**

**FIG. 4**

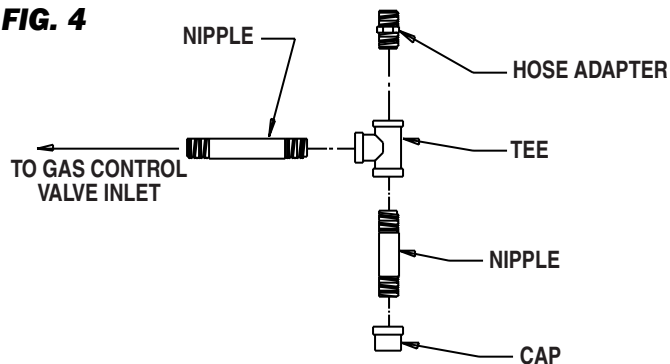

## THERMOSTAT INSTALLATION

**WARNING**  
Electrical Shock Hazard

- Disconnect the electrical supply before connecting the thermostat to the heater.
- Failure to follow this warning can result in electrical shock, leading to personal injury or death.

### 1. To Connect the Series Tap Plug Thermostat Kit:

- a. Connect the power cord of the heater to the female side of the plug on the end of the thermostat cord.
- b. Plug the male side of the series tap plug on the thermostat cord into a three-wire (grounded) electrical outlet within the building.

### 2. To Connect the Direct Wired Thermostat Kit to the Control Box on the Heater:

- a. The installation and wiring of a thermostat must be done by an electrician or someone properly qualified.
- b. The thermostat may use 18 gauge, 3 wire cord to handle the voltage being supplied to the thermostat.
- c. Follow all instructions provided with the thermostat kit.
- d. The heater must be tested for proper operation after the thermostat has been connected.

## MANUAL SHUT-OFF VALVE, HOSE AND REGULATOR ASSEMBLY

1. Always use approved pipe thread compound suitable for use with L.P. gas or natural gas on the threaded connections.
2. Assemble the components together according to the figure. This view is to show general assembly of the components only. The regulator must always be mounted so its vent, regardless of location on the regulator, is always pointed downward.
3. Tighten all connections securely.

**FIG. 5**

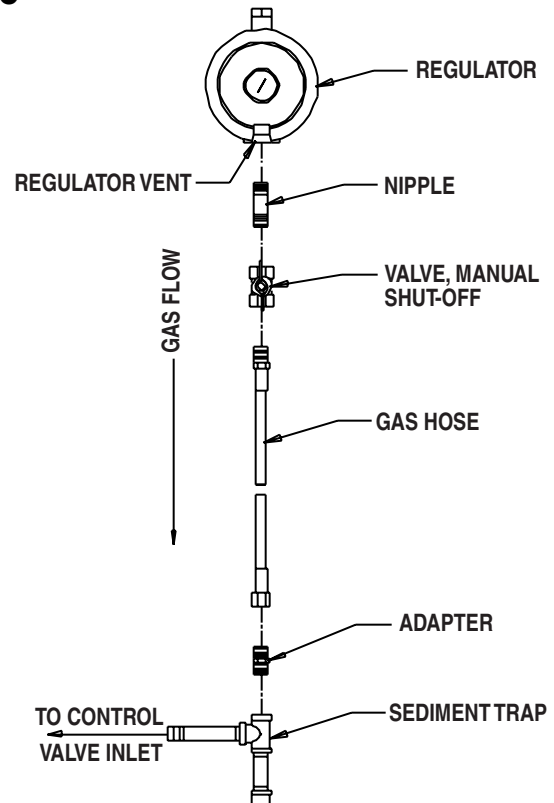

## Start-Up Instructions

Follow steps 1 - 8 on initial start-up after heater installation by a qualified gas heater service person. For normal start-up, simply turn thermostat above room temperature. The heater will start.

1. Open all manual fuel supply valves and check for gas leaks using approved certified leak detectors.
2. The gas control valve incorporates a manual gas shut off feature. Position the indicator on the shut off knob to pilot.
3. Fully depress the red pilot button located on the control valve while applying flame to the pilot light.
4. Keep the button depressed for about 30 seconds to allow the thermocouple to warm up so the pilot stays lit after you release the pilot button. On new installations it may take about a minute for the gas to purge out any air in the pilot line before the pilot lights.
5. Position the knob to on.

**FIG. 6**



6. Connect the heater's electrical cord to an approved electrical outlet.
7. Set thermostat to a point above room temperature. the heater will light. Reset thermostat to desired room temperature.
8. Do not exceed input rating stamped on nameplate of appliance, or manufacturer's recommended burner orifice pressure for size orifice(s) used.

## Shut-Down Instructions

If the heater is to be shut down for cleaning, maintenance or repair, follow steps 1 - 5. Otherwise, simply turn thermostat to off or no heat for standard shut down.

1. Close all manual fuel supply valves.
2. With the heater lit, allow heater to burn off excess fuel in gas supply hose.
3. Turn the knob (if applicable) on the gas control to off.
4. Turn thermostat to off or no heat position.
5. Disconnect the heater from the electrical supply.

## Variable Heat Output

1. Some models of propane (LP) gas or natural gas heaters have a throttle valve for varying heat output located between the gas control valve and gas manifold assemblies. THIS IS NOT A MANUAL GAS SHUT OFF VALVE.
2. The throttle valve can be adjusted to deliver either minimum heat or maximum heat. When the throttle valve handle is parallel to the gas flow, the valve is

completely open to deliver maximum heat output. (Refer to Fig. 7.)

The throttle valve may be adjusted to minimum heat output by turning the handle 90° to gas flow or any position between maximum and minimum settings. (Refer to Fig. 8.)

**FIG. 7**

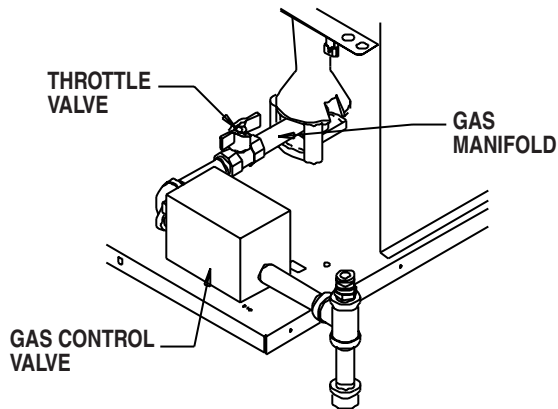

**FIG. 8**

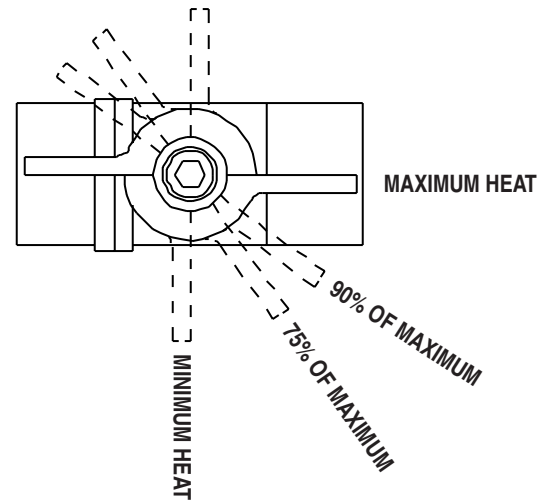

## Cleaning Instructions



### **WARNING** Fire, Burn, and Explosion Hazard

- This heater contains electrical and mechanical components in the gas management, safety and airflow systems.
- Such components may become inoperative or fail due to dust, dirt, wear, aging, or the corrosive atmosphere of an animal confinement building.
- Periodic cleaning and inspection as well as proper maintenance are essential to avoid serious injury or property damage.

1. Before cleaning, shut off all gas supply valves and disconnect electrical supply.
2. The heater should have dirt or dust removed periodically:
  - a. After each flock or between building re-population, give the heater a general cleaning using compressed air or a soft brush on its interior and exterior. At this time, dust off the motor case to prevent the motor from over-heating and shutting the heater down.
  - b. At least once a year, give the heater a thorough cleaning. At this time, remove the fan and motor assembly and brush or blow off the fan wheel, giving attention to the individual fan blades. Additionally, make sure the burner air inlet venturi ports and the “throat” of the casting are free of dust accumulation and the area between the heat chamber top and inside case is also free of dust.
  - c. When washing with water, observe and obey the Warning within these Cleaning Instructions. This same Warning is also supplied on the heater.



### **WARNING**

This heater may be washed only on the external case assembly provided:

- A. The heater is disconnected from the electrical supply.
- B. All access panels are securely closed.
- C. Water spray nozzle shall not discharge within 6 feet of the heater.
- D. The water pressure does not exceed 45 PSIG for 10 seconds on each side of heater.
- E. The heater is not reconnected to electrical supply for a minimum of 1 hour or until the heater is thoroughly dry.

Improper cleaning of the heater can cause severe personal injury or property damage due to water and/or cleaning solution:

1. In electrical components, connections and wires causing electrical shock or component failure.
2. On gas control components causing corrosion which can result in gas leaks and fire or explosion from the leak.

Clean internal components of the heater with a soft, dry brush or cloth, or compressed air.

## Maintenance Instructions

1. Have your gas supplier check all gas piping annually for leaks or restrictions in gas lines. Also, at this time have your gas supplier clean out the sediment trap of any debris that may have accumulated.
2. **The appliance area shall be kept clear and free from combustible materials, gasoline, and other flammable vapors and liquids.**
3. Regulators can wear out and function improperly. Have your gas supplier check the date codes on all regulators installed and check delivery pressures to the appliance to make sure that the regulator is reliable.
4. Regulators must be periodically inspected to make sure the regulator vents are not blocked. Debris, insects, insect nests, snow, or ice on a regulator can block vents and cause excess pressure at the appliance.

# Electrical Connection and Ladder Diagram

## CAUTION

Always refer to the heater's electrical connection diagram when servicing to avoid wiring errors and heater malfunction. Check for proper operation after servicing.

### WARNING: THIS HEATER MAY START AT ANY TIME

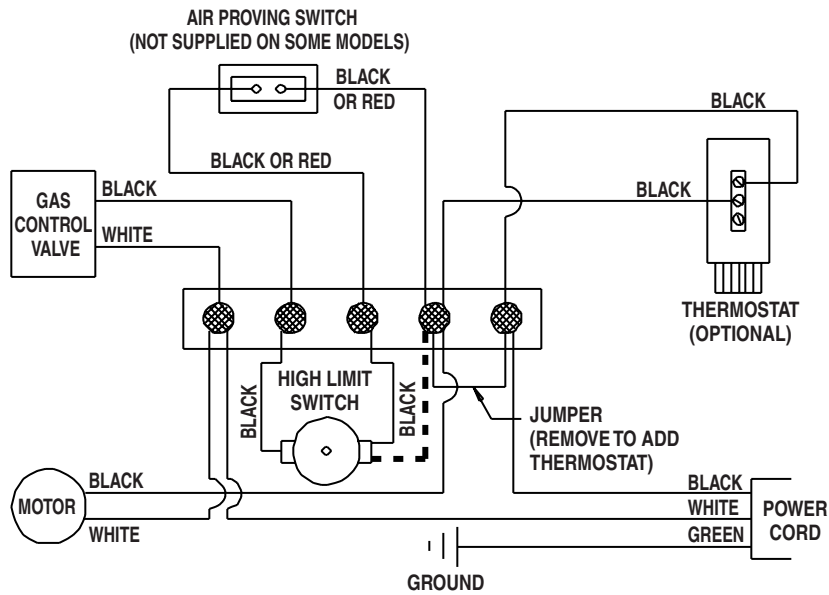

NOTE: IF AIR PROVING SWITCH IS NOT SUPPLIED, POWER IS SENT DIRECTLY TO HIGH LIMIT SWITCH. SEE "DASHED" LINE.

### ELECTRICAL CONNECTION DIAGRAM

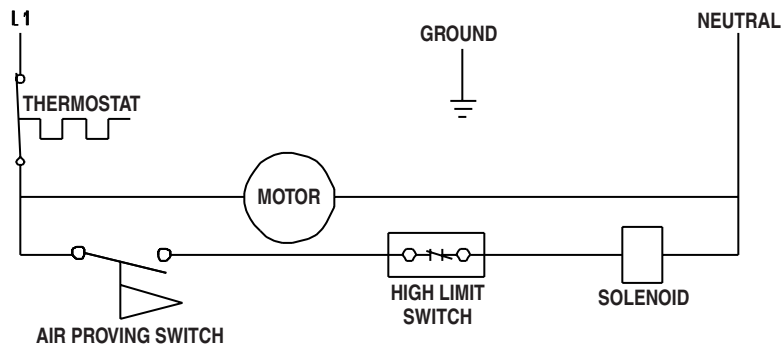

### ELECTRICAL LADDER DIAGRAM

IF ANY OF THE ORIGINAL WIRE AS SUPPLIED WITH THE APPLIANCE MUST BE REPLACED, IT MUST BE REPLACED WITH WIRING MATERIAL HAVING A TEMPERATURE RATING OF AT LEAST 302° F (150° C).

---

# Heater Component Function

## **Air Proving Switch**

Safety device used to insure that the proper air flow is being achieved before the gas valve is opened.

## **Burner**

Cast iron component used to channel gas and provide an area at which the fuel may ignite.

## **Burner Orifice**

Brass metering device used to feed gas to burner at a specific rate.

## **Fan Housing**

Chamber used for compressing air for efficient air movement.

## **Fan Wheel**

Component used in conjunction with the motor and fan housing to pull the hot air from heater and blow it into room for heating (also known as a “squirrel cage”).

## **Gas Hose**

Flexible connector used to convey gas from supply line in building to heater.

## **Heat Chamber**

Metal fire box within the appliance that provides an area where burner flame mixes with combustion air thereby providing heat.

## **High Limit Switch**

Safety device wired into the control system which is used to break an electrical circuit to the gas control valve in event of overheat situation.

## **Motor**

Electric device used to force preheated air through the heater and to circulate heat within a certain area. Converts electrical energy into mechanical energy.

## **Pilot Light Orifice**

A metering device used to supply gas for the dual purpose of igniting the main burner and heating the thermocouple.

## **Pilot Safety Control Valve**

A gas control valve which is held open by electrical power supplied by a pilot generator and which closes automatically to shut off the flow of gas to the main burner when the pilot flame is extinguished or becomes too small to light the main burner.

## **Pilot Shield**

A formed sheet metal piece that fits around the pilot assembly to protect the the pilot flame against drafts.

## **Pilot Tube**

Formed copper tube used to convey gas from the safety control valve to the pilot light orifice. The tube is internally “tinned” when natural gas is used to resist the effects of sulphur in the fuel.

## **Regulator**

The heart of any gas supply installation. Used to deliver a working pressure to the appliance under varying conditions in tank pressure.

## **Thermocouple**

A thermoelectric device that converts heat energy directly into electrical energy. Works in conjunction with the electromagnet in the gas control valve thereby providing gas supply for the pilot light.

## **Thermostat**

Electrical device used as an automatic on/off switch which will respond to changes in temperature in a certain area. Can be wired so contacts in the thermostat open or close on temperature increase or decrease.

## **Throttle Valve**

Manually adjustable component used to increase or decrease the flow of gas to the burner. The throttle valve is located between the gas control valve and burner assembly.

# Parts Identification

## Parts Schematic

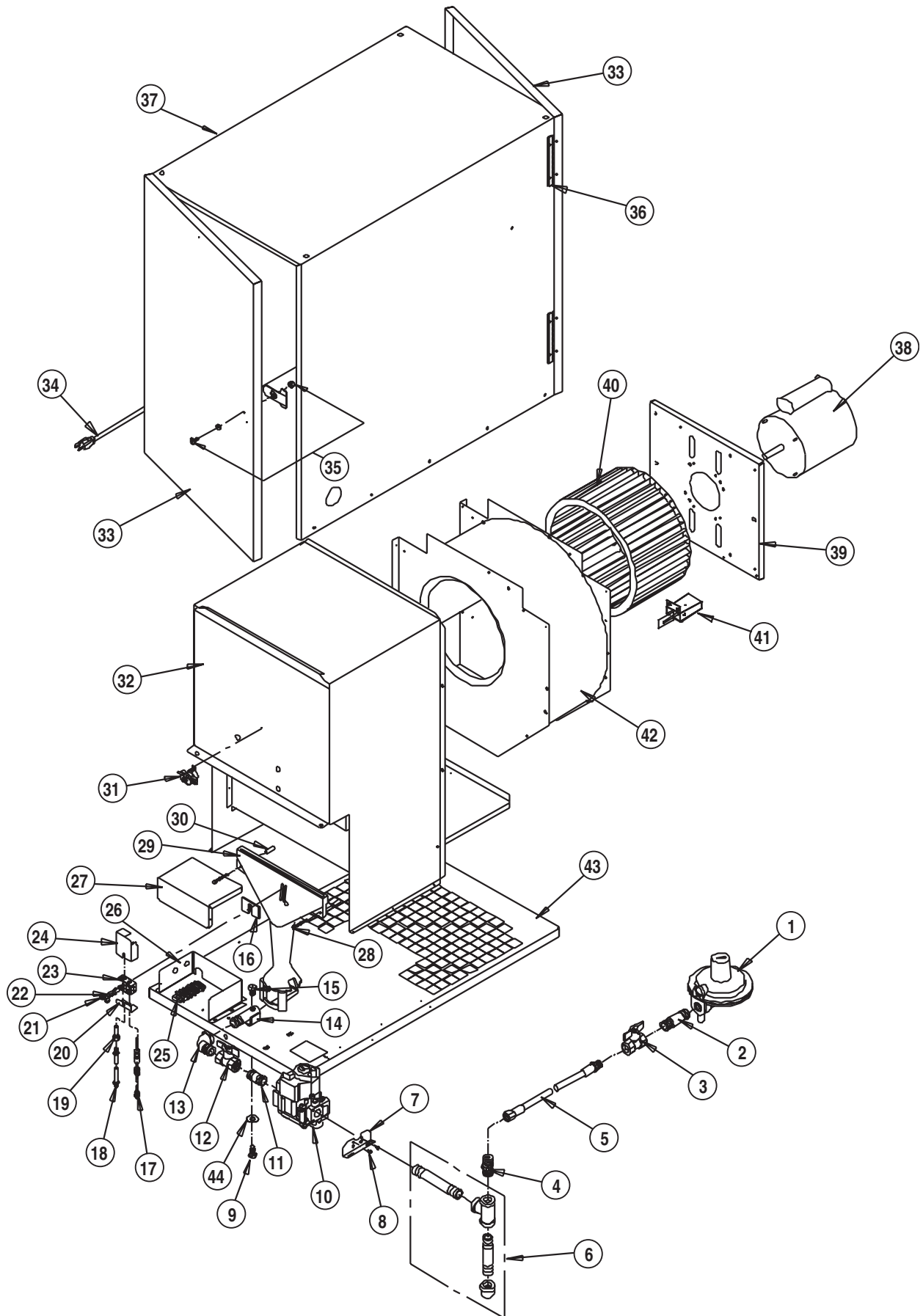

---

**Parts List**

<b>Item</b>	<b>Description</b>	<b>Part Number</b>
1	Regulator, Second Stage (LP Gas)	06665
	Regulator, Second Stage (Nat. Gas)	23360
2	Nipple, 3 1/2 in.	07148
3	Valve, Manual Shut-Off	05548
4	Hose, 1/2 in. x 10 ft.	20714
5	Adapter, 1/2 NPT x 1/2 NPS	02894
6	Sediment Trap	00815
7	Bracket	21768
8	Screw	09425
9	Bolt	02692
10	Valve, Gas Control (LP Gas)	20439
	Valve, Gas Control (Natural Gas)	20440
11	Nipple	02420
12	Valve, Throttle (LP Gas)	20143
	Valve, Throttle (Natural Gas)	20144
13	Elb, Street	01359
14	Manifold	09291
15	Orifice, Burner (LP Gas)	20141
	Orifice, Burner (Natural Gas)	20142
16	Gasket	06974
17	Thermocouple, 21 in.	03497
18	Tubing, Pilot	20436
19	Orifice, Pilot (LP Gas)	07829
	Orifice, Pilot (Natural Gas)	06968
20	Cover, Bottom	20265
21	Screw, Wing	07484
22	Stud	07827
23	Pilot Bracket	07831
24	Shield with Pilot Stack	20264
25	Terminal Strip	08253
26	Enclosure, Electrical	20028
27	Cover, Enclosure	20027
28	Screw	02688
29	Burner	03453
30	Spacer	02687
31	Switch, High Limit	05566
32	Chamber, Heat	20024
33	Door (Either End)	20757
34	Cord, Power	20426
35	Latch	09467
36	Hinge	05868
37	Case Assembly (1)	20434
38	Motor	20169
39	Mount, Motor	08467
40	Wheel, Fan	09050
41	Air Flow Switch Assembly	24157
42	Housing with Air Flow Switch Assembly and Motor Mount	24167
43	Base	20431
44	Washer	01589

(1) Specify model number and fuel type when ordering.

(2) For fix rate heater, replace items 11, 12 and 13, with a 1/2 in. elbow - part #01426;  
and a nipple, 1/2 in. x 3 1/2 in. - part #07148

---

# Warranty Policy

---

## EQUIPMENT

L.B. White Co., Inc. warrants that the component parts of its equipment are free from defects in material and workmanship, when properly installed, operated, and maintained in accordance with the Installation and Maintenance Instructions, safety guides and labels contained with each unit. If, **within 12 months from the date of purchase by the end user**, any component is found to be defective, L.B. White Co., Inc. will at its option, repair

or replace the defective part or equipment, with a new part or equipment, F.O.B., Onalaska, Wisconsin.

A warranty card on file at L.B. White will automatically qualify a unit and its component parts for warranty consideration. If a warranty card is not on file, a copy of the bill of sale will be required to establish warranty qualification. If neither is available, the warranty period will be 12 months from date of shipment from L.B. White.

---

## PARTS

L.B. White Co., Inc. warrants that replacement parts purchased from the company and used on the appropriate L. B. White equipment are free from defects both in material and workmanship for **12 months from the date of purchase by the end user**. Warranty is automatic if a component is found defective within 12 months of the date code marked on the part. If the defect occurs more than 12 months later than the date code but within 12 months from the date of purchase by the end user, a copy of a bill of sale will be required to establish warranty qualification.

duration to the duration of the applicable warranty stated above. The remedies set forth above are the sole and exclusive remedies available hereunder. L.B. White will not be liable for any incidental or consequential damages directly or indirectly related to the sale, handling or use of the equipment, and in any event L.B. White's liability in connection with the equipment, including for claims based on negligence or strict liability, is limited to the purchase price.

The warranty set forth above is the exclusive warranty provided by L.B. White, and all other warranties, including any implied warranties or merchantability or fitness for a particular purpose, are expressly disclaimed. In the event any implied warranty is not hereby effectively disclaimed due to operation of law, such implied warranty is limited in

Some states do not allow limitations on how long an implied warranty lasts, so the above limitation may not apply to you. Some states do not allow the exclusion or limitation of incidental or consequential damages, so the above limitation or exclusion may not apply to you. This warranty gives you specific legal rights, and you may also have other rights which vary from state to state.

---

## Replacement Parts and Service

Contact your local L.B. White dealer for replacement parts and service or call L.B. White Co., Inc. at 1-800-345-7200 for

assistance. Be sure that you have your heater model number and configuration number when calling.