



Owner's Manual and Instructions

GUARDIAN® Agricultural Animal Confinement Building Heaters



MODELS	OUTPUT (Btuh)	FUEL
AD250	250,000	All Models are available in either L.P. Gas Vapor Withdrawal or Natural Gas Configurations.



Certification by:

Congratulations!

You have purchased the finest agricultural building heater available.

Your new L.B. White heater incorporates the benefits from the most experienced manufacturer of heating products using state-of-the-art technology.

We, at L.B. White, **thank you** for your confidence in our products and welcome any suggestions or comments you may have...call us, toll-free, at 1-800-345-7200.

ATTENTION ALL USERS

This heater has been tested and evaluated by C.S.A. International in accordance with ANSI/IAS U.S. LC2-1996 as well as the Canadian Gas Association Standard for Gas Fired Brooders, CAN1-2.20-M85 and is listed and approved as a direct gas-fired circulating heater for the heating of agricultural animal confinement buildings. If you are considering using this product for any application other than its intended use, then please contact your fuel gas supplier, or the L.B. White Co., Inc.



Quality heaters you can count on.

W6636 L.B. White Rd., Onalaska, WI 54650 ■ (800) 345-7200 ■ (608) 783-5691 ■ (608) 783-6115, fax ■ info@lbwhite.com

150-24207

 **GENERAL HAZARD WARNING**

- Failure to comply with the precautions and instructions provided with this heater, can result in:
 - Death
 - Serious bodily injury or burns
 - Property damage or loss from fire or explosion
 - Asphyxiation due to lack of adequate air supply or carbon monoxide poisoning
 - Electrical shock
- Read this Owner's Manual before installing or using this heater.
- Only properly-trained service people should repair or install this heater.
- Save this Owner's Manual for future use and reference.
- Owner's Manuals and replacement labels are available at no charge. For assistance, contact L.B. White at 800-345-7200.

 **WARNING**

- Proper gas supply pressure must be provided to the inlet of the heater.
- Refer to dataplate for proper gas supply pressure.
- Gas pressure in excess of the maximum inlet pressure specified at the heater inlet can cause fires or explosions.
- Fires or explosions can lead to serious injury, death, building damage or loss of livestock.
- Gas pressure below the minimum inlet pressure specified at the heater inlet may cause improper combustion.
- Improper combustion can lead to asphyxiation or carbon monoxide poisoning and therefore serious injury or death to humans.



WARNING
Fire and Explosion Hazard

- Not for home or recreational vehicle use.
- Installation of this heater in a home or recreational vehicle may result in a fire or explosion.
- Fire or explosions can cause property damage or loss of life.

CONSIGNES DE SECURITE
Il est interdit d'utiliser des liquides inflammables ou dégageant des vapeurs inflammables, a proximite de tout appareil fonctionnant au gaz.

CONSIGNES DE SECURITE

Si vous sentez une odeur de gaz:

1. Ouvrez le fenetres.
2. Ne touchez pas aux interrupteurs electriques.
3. Eteignez toute flamme nue.
4. Contactez immediatement votre compagnie de gaz.



WARNING
Fire and Explosion Hazard

- Keep solid combustibles a safe distance away from the heater.
- Solid combustibles include wood or paper products, feathers, straw, and dust.
- Do not use the heater in spaces which contain or may contain volatile or airborne combustibles.
- Volatile or airborne combustibles include gasoline, solvents, paint thinner, dust particles or unknown chemicals.
- Failure to follow these instructions may result in a fire or explosion.
- Fire or explosions can lead to property damage, personal injury or loss of life.

FOR YOUR SAFETY

Do not store or use gasoline or other flammable vapors and liquids in the vicinity of this or any other appliance.

FOR YOUR SAFETY

If you smell gas:

1. Open windows.
2. Don't touch electrical switches.
3. Extinguish any open flame.
4. Immediately call your gas supplier.



Table of Contents

<u>SECTION</u>	<u>PAGE</u>
General Information	3
Heater Specifications	4
Safety Precautions	5
Installation Instructions	
General	7
Air Diverter Installation Instructions	8
Hanging Installation Instructions	9
Sediment Trap Assembly Instructions	9
Thermostat Installation Instructions	10
Manual Shut-Off Valve, Hose and Regulator Assembly Instructions	10
Start-Up Instructions	11
Shut-Down Instructions	11
Variable Heat Output Instructions	12
Cleaning Instructions	13
Maintenance Instructions	13
Service Instructions	
Motor & Fan Assembly	14
Air Proving Switch with Paddle	14
Removal of Control Box from Heater	15
Igniter & Flame Sensor	15
Gas Pressure Checks	16
High Limit Switch	17
Troubleshooting Instructions	18
Electrical Connection and Ladder Diagram	25
Heater Component Function	26
Parts Identification (Parts List & Schematic)	27 & 28
Warranty Policy	29
Replacement Parts and Service	29

General Information

This Owner's Manual includes all options and accessories commonly used on this heater. However, depending on the configuration purchased, some options and accessories may not be included.

When calling for technical service assistance, or for other specific information, always have model number, configuration number and serial number available. This information is contained on the dataplate. The dataplate is located on the interior of either the burner end or motor end door.

This manual will instruct you in the operation and care of your unit. Have your qualified installer review this manual with you so that you fully understand the heater and how it functions.

The gas supply line installation, installation of the heater, and repair and servicing of the heater requires continuing expert training and knowledge of gas heaters and should not be attempted by anyone who is not so qualified. See page 6 for definition of the necessary qualifications. A detailed Installation and Service Guide is available, at no charge, to qualified personnel by contacting the local L.B. White distributor, dealer or the L.B. White Company.

Contact your local L.B. White distributor or the L.B. White Co., Inc. for assistance, or if you have any questions about the use of the equipment or its application.

The L.B. White Co., Inc. has a policy of continuous product improvement. It reserves the right to change specifications and design without notice.

Heater Specifications

		Model	
SPECIFICATIONS		AD250	
		L.P Gas	Natural Gas
Maximum Input (BTUH)		250,000	
Minimum Input (BTUH)		160,000	
Ventilation Air Required to Support Combustion		1,050 CFM	
Inlet Gas Supply Pressure Acceptable at the Inlet of the Heater for Purpose of Input Adjustment	MAX.	13.5 in. W.C.	
	MIN.	11 in. W.C.	7 in. W.C.
Burner Manifold Pressure		10 in. W.C.	4 in. W.C.
Fuel Consumption Per Hour	MAX.	11.58 lbs.	250 cu. ft.
	MIN.	7.41 lbs.	160 cu. ft.
Motor Characteristics		Ball Bearing	
		1/3 H.P. 1100 RPM	
Electrical Supply (Volts/Hz/Phase)		115/60/1	
Amp Draw (Starting Amps Includes Igniter)	STARTING	11.8	
	CONTINUOUS OPERATION	4.5	
Dimensions (Inches) L x W x H		30 3/4 x 18 1/4 x 28 1/4	
Minimum Safe Distances From Nearest Combustible Materials	TOP	1 ft. (.3 m)	
	SIDES	1 ft. (.3 m)	
	BACK	1 ft. (.3 m)	
	BLOWER OUTLET	6 ft. (1.83 m)	
	GAS SUPPLY	L.P. Gas Supply – 6 ft. (1.83 m) Natural Gas Supply – N/A	
Net Weight (lbs.)		116	
Shipping Weight (lbs.)		126	

Safety Precautions

WARNING **Asphyxiation Hazard**

- Do not use this heater for heating human living quarters.
- Do not use in unventilated areas.
- The flow of combustion and ventilation air must not be obstructed.
- Proper ventilation air must be provided to support the combustion air requirements of the heater being used.
- Refer to the specification section of the heater's Owner's Manual, heater dataplate, or contact the L.B. White Company to determine combustion air ventilation requirements of the heater.
- Lack of proper ventilation air will lead to improper combustion.
- Improper combustion can lead to carbon monoxide poisoning in humans leading to serious injury or death. Symptoms of carbon monoxide poisoning can include headaches, dizziness and difficulty in breathing.
- Symptoms of improper combustion affecting livestock can be disease, lower feed conversion, or death.

FUEL GAS ODOR

LP gas and natural gas have man-made odorants added specifically for detection of fuel gas leaks.

If a gas leak occurs, you should be able to smell the fuel gas.

THAT'S YOUR SIGNAL TO GO INTO IMMEDIATE ACTION!

- Do not take any action that could ignite the fuel gas. Do not operate any electrical switches. Do not pull any power supply or extension cords. Do not light matches or any other source of flame. Do not use your telephone.
- Get everyone out of the building and away from the area immediately.
- Close all propane (LP) gas tank or cylinder fuel supply valves, or the main fuel supply valve located at the meter if you use natural gas.
- Propane (LP) gas is heavier than air and may settle in low areas. When you have reason to suspect a propane leak, keep out of all low areas.
- Natural gas is lighter than air and can collect around rafters or ceilings.
- Use your neighbor's phone and call your fuel gas supplier and your fire department. Do not re-enter the building or area.
- Stay out of the building and away from the area until declared safe by the firefighters and your fuel gas supplier.
- **FINALLY**, let the fuel gas service person and the firefighters check for escaped gas. Have them air out the building and area before you return. Properly trained service people must repair the leak, check for further leakages, and then relight the appliance for you.

ODOR FADING -- NO ODOR DETECTED

- **Some people cannot smell well. Some people cannot smell the odor of the man-made chemical added to propane (LP) or natural gas. You must determine if you can smell the odorant in these fuel gases.**
- Learn to recognize the odor of propane (LP) gas and natural gas. Local propane (LP) gas dealers and your local natural gas supplier (utility) will be more than happy to give you a scratch and sniff pamphlet. Use it to become familiar with the fuel gas odor.
- Smoking can decrease your ability to smell. Being around an odor for a period of time can affect your sensitivity to that particular odor. Odors present in animal confinement buildings can mask fuel gas odor.
- **The odorant in propane (LP) gas and natural gas is colorless and the intensity of its odor can fade under some circumstances.**
- If there is an underground leak, the movement of gas through the soil can filter the odorant.
- Propane (LP) gas odor may differ in intensity at different levels. Since propane (LP) gas is heavier than air, there may be more odor at lower levels.
- **Always be sensitive to the slightest gas odor.** If you continue to detect any gas odor, no matter how small, treat it as a serious leak. Immediately go into action as discussed previously.

ATTENTION -- CRITICAL POINTS TO REMEMBER!

- Propane (LP) gas and natural gas have a distinctive odor. Learn to recognize these odors. (Reference Fuel Gas Odor and Odor Fading sections above.)
- If you have not been properly trained in repair and service of propane (LP) gas and natural gas fueled heaters, then do not attempt to light heater, perform service or repairs, or make any adjustments to the heater on propane (LP) gas or natural gas fuel system.
- Even if you are not properly trained in the service and repair of the heater, ALWAYS be consciously aware of the odors of propane (LP) gas and natural gas.
- A periodic sniff test around the heater or at the heater's joints; i.e. hose, connections, etc., is a good safety practice under any conditions. If you smell even a small amount of gas, CONTACT YOUR FUEL GAS SUPPLIER IMMEDIATELY. DO NOT WAIT!

1. Do not attempt to install, repair, or service this heater or the gas supply line unless you have continuing expert training and knowledge of gas heaters.

Qualifications for service and installation of this equipment are as follows:

- a. To be a qualified gas heater service person, you must have sufficient training and experience to handle all aspects of gas-fired heater installation, service and repair. This includes the task of installation, troubleshooting, replacement of defective parts and testing of the heater. You must be able to place the heater into a continuing safe and normal operating condition. You must completely familiarize yourself with each model heater by reading and complying with the safety instructions, labels, Owner's Manual, etc., that is provided with each heater.
 - b. To be a qualified gas installation person, you must have sufficient training and experience to handle all aspects of installing, repairing and altering gas lines, including selecting and installing the proper equipment, and selecting proper pipe and tank size to be used. This must be done in accordance with all local, state and national codes as well as the manufacturer's requirements.
2. All installations and applications of L.B. White heaters must meet all relevant local, state and national codes. Included are L.P. gas, natural gas, electrical, and safety codes. Your local fuel gas supplier, a local licensed electrician, the local fire department or similar government agencies, or your insurance agent can help you determine code requirements.
 - a. For U.S.A. installations and applications:
 - ANSI/NFPA 58, latest edition, Standard for Storage and Handling of Liquefied Petroleum Gas and/or
 - ANSI Z223.1/NFPA 54, National Fuel Gas Code
 - ANSI/NFPA 70, National Electrical Code.
 - b. For Canadian Installations and Applications:
 - CAN1-B149.1 or CAN1-B149.2 Installation Codes
 - CSA C22.1 Part 1 Standard Canadian Electrical Code. CSA C22.2 No. 3, Electrical Features of Fuel-Burning Equipment.
 3. Do not move, handle, or service heater while in operation or connected to a power or fuel supply.
 4. This heater may be installed in areas subject to washdown. This heater may only be washed on the external case assembly—see Cleaning Instructions. Do not wash the interior of the heater. Use only compressed air, soft brush or dry cloth to clean the interior of the heater and it's components. After external washdown, do not operate this heater until it is completely dry. In any event, do not operate the heater for at least one hour after external washdown.

5. For safety, this heater is equipped with a manual reset high-limit switch and an air proving switch. Never operate this heater with any safety device that has been bypassed. Do not operate this heater unless all of these features are fully functioning.
6. Do not operate the heater with its door open or panel removed.
7. Do not locate fuel gas containers or fuel supply hoses anywhere near the blower outlet of the heater.
8. Do not block air intakes or discharge outlets of the appliance. Doing so may cause improper combustion or damage to heater components leading to property damage or animal loss.
9. The hose assembly (if provided) shall be visually inspected on an annual basis. If it is evident there is excessive abrasion or wear, or if the hose is cut, it must be replaced prior to the heater being put into operation. The hose assembly shall be protected from animals, building materials, and contact with hot surfaces during use. The hose assembly shall be that specified by the manufacturer. See parts list.
10. Check for gas leaks and proper function upon heater installation, before building repopulation or when relocating.
11. This heater should be inspected for proper operation by a qualified service person before building repopulation and at least annually.
12. Always turn off the gas supply to the appliance if the appliance is not going to be used in the heating of livestock.
13. This heater is equipped with a three-prong (grounding) plug for your protection against shock hazard and must be plugged directly into a properly grounded three-prong receptacle. Failure to use a properly grounded receptacle can result in electrical shock, personal injury, or death.
14. Direct ignition heaters will make up to three trials for ignition. If ignition is not achieved, the control system will lock out the gas control valve. If gas is smelled after system lock out has occurred, immediately close all fuel supply valves. Do not relight until you are sure that all gas that may have accumulated has cleared away. In any event, do not relight for at least 5 minutes.
15. In a hanging type installation, rigid pipe or copper tubing coupled directly to the heater may cause gas leaks during movement, and therefore must not be used. Use only gas hose assemblies that are rated and approved for L.P.gas and natural gas in a hanging type of installation.
16. Installations not using the gas hose supplied with this appliance must connect dimensionally using American National Standard Wrought Steel and Wrought Iron Pipe B36/10-1970. (Aluminum piping or tubing shall not be used.) Copper tubing when used for conveying natural gas, shall be internally tinned or equivalently treated to resist sulphur.

Installation Instructions

GENERAL



WARNING

Fire or explosion hazard.

Can cause property damage, severe injury or death.

1. Disconnect power supply before wiring to prevent electrical shock or equipment damage.
2. To avoid dangerous accumulation of fuel gas, turn off gas supply at the appliance service valve before starting installation, and perform gas leak test after completion of installation.
3. Do not force the gas control knob. Use only your hand to turn the gas control knob. Never use any tools. If the knob will not operate by hand, the control should be replaced by a qualified service technician. Force or attempted repair may result in fire or explosion.

1. Read all safety precautions and follow L. B. White recommendations when installing this heater. If during the installation or relocating of heater, you suspect that a part is damaged or defective, call a qualified service agency for repair or replacement.
2. Make sure the heater is properly positioned before use and is hung level. Observe and obey all minimum safe distances of the heater to the nearest combustible materials. Minimum safe distances are given on the heater nameplate and on page 4 of this manual.
3. For heaters intended for outdoor installation, the heater is to be installed at least 18 inches above the ground or to a height that would prevent snow blockage of heater's air inlet.
4. The heater may be used either indoors or outdoors. When the heater is mounted outdoors, use only the ductwork supplied in the outdoor mounting kit.
5. The heater must have the proper gas regulator installed for the application. A regulator must be connected to the gas supply so that gas pressure at the inlet to the gas valve is regulated within the range specified on the dataplate at all times. Contact your gas supplier, or the L.B. White Co., Inc. if you have any questions.
6. The heater's gas regulator (with pressure relief valve) should be installed outside of building. Any regulators inside the buildings must be properly vented to the outside. Local, state and national codes always apply to regulator installation. Natural gas regulators with vent limiting device may be mounted indoors without venting to outdoors.
7. All gas pressure regulators must be installed in strict accordance with the manufacturer's safety instructions. These instructions accompany each regulator.
8. Insure that all accessories that ship within the heater have been removed from inside of heater and installed. This pertains to air diverters, hose, regulators, etc.

9. Make certain that a sediment trap is installed at the gas valve inlet to prevent foreign materials (pipe compound, pipe chips and scale) from entering the gas valve. Debris blown into the gas valve may cause that valve to malfunction resulting in a serious gas leak that could result in a possible fire or explosion causing loss of products, building or even life. A properly installed sediment trap will keep foreign materials from entering the gas valve and protect the safe functioning of that important safety component.
10. Any heater connected to a piping system must have an accessible, approved manual shut off valve installed within six feet (6 ft.) of the appliance it serves.
11. Check all connections for gas leaks using approved gas leak detectors. Gas leak testing is performed as follows:



WARNING

Fire and Explosion Hazard

- Do not use open flame (matches, torches, candles, etc.) in checking for gas leaks.
- Use only approved leak detectors.
- Failure to follow this warning can lead to fires or explosions.
- Fires or explosions can lead to property damage, personal injury or loss of life.

- Check all pipe connections, hose connections, fittings and adapters upstream of the gas control with approved gas leak detectors.
- In the event a gas leak is detected, check the components involved for cleanliness and proper application of pipe compound before further tightening.
- Furthermore tighten the gas connections as necessary to stop the leak.
- After all connections are checked and any leaks are stopped, turn on the main burner.
- Stand clear while the main burner ignites to prevent injury caused from hidden leaks that could cause flashback.
- With the main burner in operation, check all connections, hose connections, fittings and joints as well as the gas control valve inlet and outlet connections with approved gas leak detectors.
- If a leak is detected, check the components involved for cleanliness in the thread areas and proper application of pipe compound before further tightening.
- Tighten the gas connection as necessary to stop the leak.
- If necessary, replace the parts or components involved if the leak cannot be stopped.
- Ensure all gas leaks have been identified and repaired before proceeding.

12. A qualified service agency must check for proper operating gas pressure upon installation of the heater.
13. Light according to instructions on heater or within owner's manual.
14. It is extremely important to use the proper size and type of gas supply line to assure proper functioning of the heater. Contact your fuel gas supplier for proper line sizing and installation.
15. This heater can be configured for use with either L.P. gas vapor withdrawal or natural gas. Consult the dataplate, located on interior of the burner end or motor end door, for the gas configuration of the specific heater. Do not use the heater in an L.P. gas liquid withdrawal system or application. If you are in doubt, contact the L.B. White Co., Inc.
16. Eventually, like all electrical/mechanical devices, the thermostat can fail. Thermostat failure may result in either an underheating or overheating condition which may damage critical products and/or cause

animal injury or death. Critical products and/or animals should be protected by a separate back-up control system that limits high and low temperatures and also activates appropriate alarms.

17. Take time to understand how to operate and maintain the heater by using this Owner's Manual. Make sure you know how to shut off the gas supply to the building and also to the individual heater. Contact your fuel gas supplier if you have any questions.
18. Any defects found in performing any of the service or maintenance procedures must be eliminated and defective parts replaced immediately. The heater must be retested by properly qualified service personnel before placing the heater back into use.
19. Do not exceed input rating stamped on the dataplate of the heater. Do not exceed the burner manifold pressure stated on the dataplate. Do not use an orifice size different than specified for the specific input rating of this heater, fuel type configuration and altitude.

AIR DIVERTER INSTALLATION INSTRUCTIONS

(Optional accessory on some models.)

(Appearance of the outlet on heater may vary from model to model.)

1. Optional air diverters can be installed in the heater outlet to provide direction to the heated air as it exits the heater. Installation options include installing the diverters in such a way as to broadly distribute the air in two 45 degree paths or to focus the air flow in one 45 degree direction. See Fig. 1.
2. The air diverters may require hand forming prior to installation. Make 90 degree bends utilizing the perforations provided. Diverter should then have the shape shown in Fig. 1.
3. The air diverter's tabs on each half will pop into the blower outlet between the inside of the case assembly and the blower housing outlet. If the notched tabs do not pop into the blower outlet, loosen (do not remove) the blower outlet screws. Doing this provides a gap into which you can insert the tabs. Retighten the screws after installation.

FIG. 1 (Typical installation allowing two directions of air movement.)

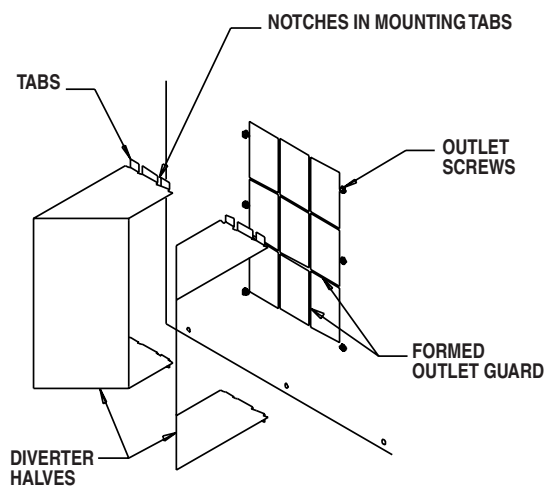

Alternate Air Diverter Installations



HANGING INSTRUCTIONS

1. Assemble according to the illustration and tighten all eyebolts securely. (See Fig. 2):

FIG. 2

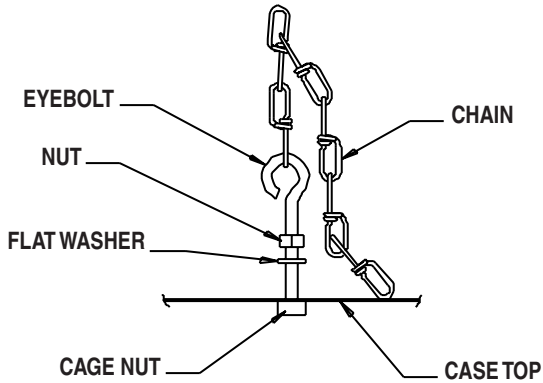

2. Be sure heater is securely fastened and is hanging level. (Check crosswise and lengthwise.)
3. See Fig. 3 for **typical** indoor installation. In any animal confinement building, consideration must be given to making sure the heater is located away from the livestock so that livestock cannot knock the heater, tear it loose from its mounting, or damage the heater or its gas supply line in any way. Make sure you observe and obey minimum clearance distances to combustible materials as stated in the specification section of this owner's manual and on the heater itself.

FIG. 3

NOTE: REGULATORS SHOULD ALWAYS BE MOUNTED OUTDOORS. IF CIRCUMSTANCES FORCE INSTALLING THE REGULATOR INDOORS, THE REGULATOR'S VENT MUST BE VENTED OUTDOORS USING VENT LINE NO SMALLER THAN VENT OPENING.

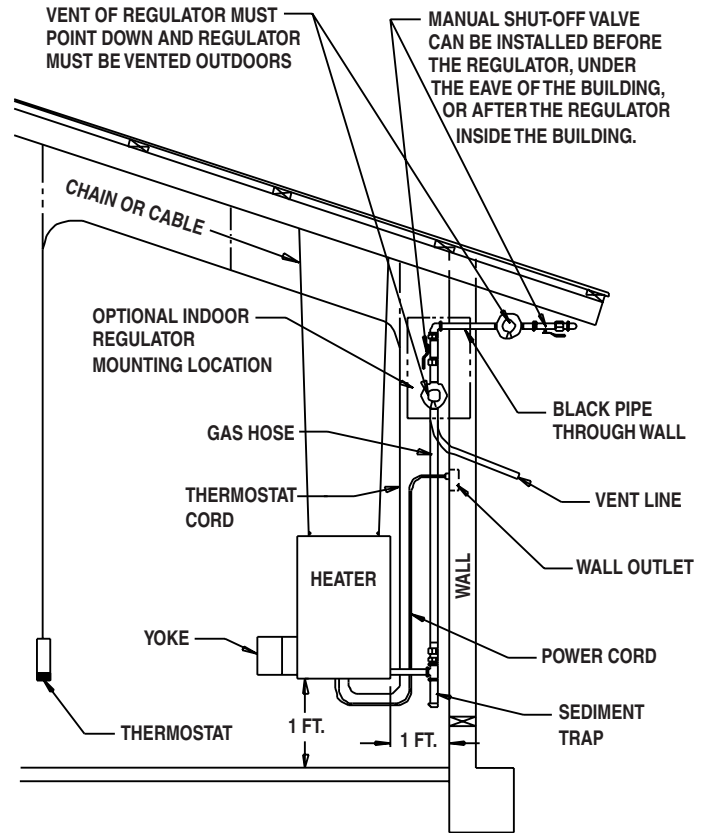

SEDIMENT TRAP ASSEMBLY

Assemble the tee, nipples and cap together and tighten securely. See Fig. 4. The sediment trap assembly must always be mounted in a vertical position. Make sure pipe thread compound that is resistant to both L.P. gas and natural gas is used in making all connections. **Check all connections for gas leaks using approved gas leak detectors.**

FIG. 4

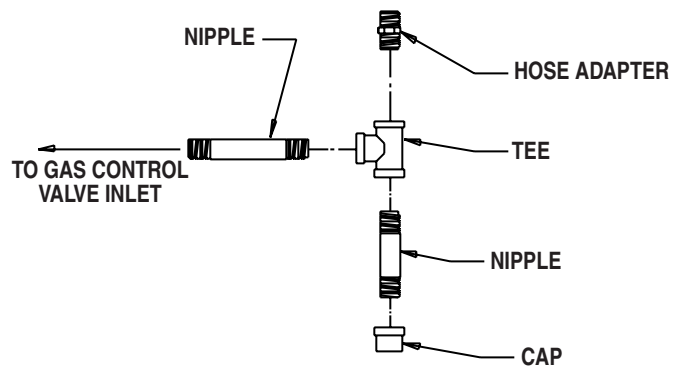

THERMOSTAT INSTALLATION

WARNING
Electrical Shock Hazard

- Disconnect the electrical supply before connecting the thermostat to the heater.
- Failure to follow this warning can result in electrical shock, leading to personal injury or death.

1. To Connect the Series Tap Plug Thermostat Kit:

- a. Connect the power cord of the heater to the female side of the plug on the end of the thermostat cord.
- b. Plug the male side of the series tap plug on the thermostat cord into a three-wire (grounded) electrical outlet within the building.

2. To Connect the Direct Wired Thermostat Kit to the Control Box on the Heater:

- a. The installation and wiring of a thermostat must be done by an electrician or someone properly qualified.
- b. The thermostat may use 18 gauge, 2 wire cord to handle the low voltage being supplied to the thermostat from the transformer.
- c. Follow all instructions provided with the thermostat kit.
- d. The heater must be tested for proper operation after the thermostat has been connected.

MANUAL SHUT-OFF VALVE, HOSE AND REGULATOR ASSEMBLY

1. Always use approved pipe thread compound suitable for use with L.P. gas or natural gas on the threaded connections.
2. Assemble the components together according to the figure. This view is to show general assembly of the components only. The regulator must always be mounted so its vent, regardless of location on the regulator, is always pointed downward.
3. Tighten all connections securely.
4. **Check all connections for gas leaks using approved gas leak detectors.**

FIG. 5

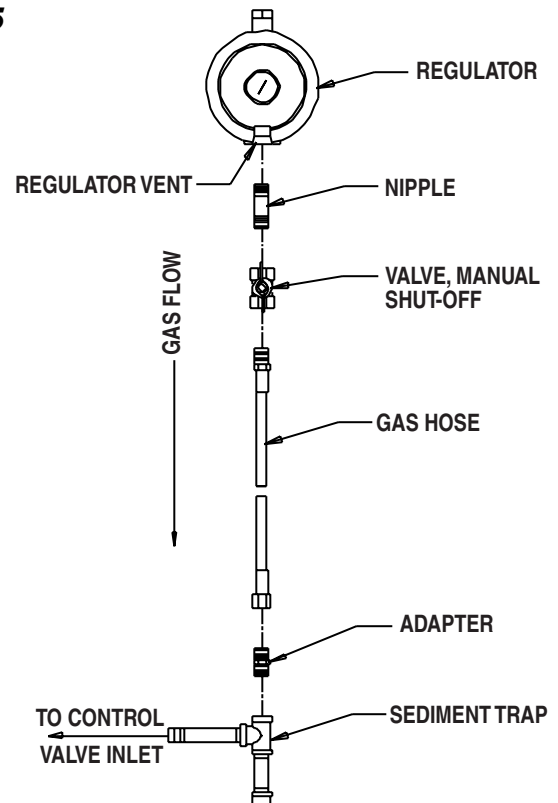

Start-Up Instructions

Follow steps 1 - 6 on initial start-up after heater installation by a qualified gas heater service person. For normal start-up, simply turn thermostat above room temperature. The heater will start.

1. Open all manual fuel supply valves and check for gas leaks using approved leak detectors. The gas control valve on the heater has a manual shut-off feature incorporated into the valve assembly. Make sure the indicator on the valve is turned to the “on” position. See Fig. 6.

FIG. 6

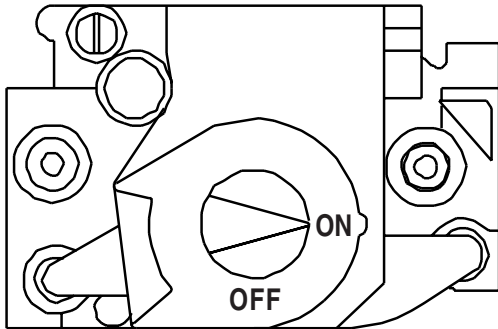

2. Connect the electrical cord to an approved electrical outlet.
3. Set the thermostat (if supplied) to desired room temperature.
4. This heater includes a direct ignition control module for purposes of controlling the timing of the ignition process of the heater as well as monitoring of the safety functions. The control module is contained within the control enclosure. On the control module

is a red light emitting diode (LED). This LED indicates the status of the heater. The LED is visible external of the control enclosure through the plastic eye. A constant light from the LED is an indicator that the heater is functioning correctly. Any flash pattern by the LED is indicative that there is a problem in the operation of the heater. Refer to the troubleshooting decal on the access panel at the fan motor end of the heater for assistance in troubleshooting. Only qualified and properly trained personnel shall service or repair the heater.

5. On a call for heat, the motor will start up and run for five (5) seconds. This “pre-purge” is a safety feature and a normal operational characteristic prior to ignition taking place. After five (5) seconds, the igniter will begin to start.

NOTE: It is normal for air to be trapped in the gas hose on new installations. The heater may attempt more than one trial for ignition before the air is finally purged from the line and ignition takes place.

6. The ignition control will make up to three trials for ignition. Each trial for ignition will take approximately ten (10) seconds. The first three trials for ignition will occur within 40 seconds if ignition is not achieved. A 15 minute “wait period” will then begin after the third trial for ignition has taken place. After the 15 minute time span has elapsed, three more trials for ignition will take place. If ignition is not achieved at this final trial, the system will “lock out”, and a three flash pattern will be indicated by the LED.

Shut-Down Instructions

If the heater is to be shut down for cleaning, maintenance or repair, follow steps 1 - 5. Otherwise, simply turn thermostat to “off” or “no heat” for standard shut down.

1. Close all manual fuel supply valves.
2. With the heater lit, allow heater to burn off excess fuel in gas supply hose.

3. Turn the indicator on the gas control to “off”.
4. Turn thermostat to “off” or “no heat” position.
5. Disconnect the heater from the electrical supply.

Variable Heat Output

1. Some models of propane (LP) gas or natural gas heaters have a throttle valve for varying heat output located between the gas control valve and gas manifold assemblies. THIS IS NOT A MANUAL GAS SHUT OFF VALVE.
2. The throttle valve can be adjusted to deliver either minimum heat or maximum heat. When the throttle valve handle is parallel to the gas flow, the valve is completely open to deliver maximum heat output. (Refer to Fig. 7.)

FIG. 7

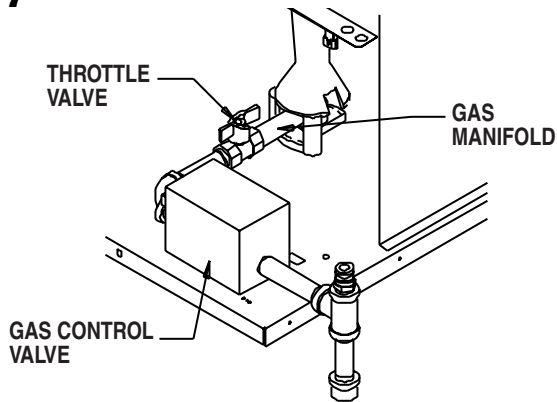

The throttle valve may be adjusted to minimum heat output by turning the handle 90° to gas flow or any position between maximum and minimum settings. (Refer to Fig. 8.)

FIG. 8

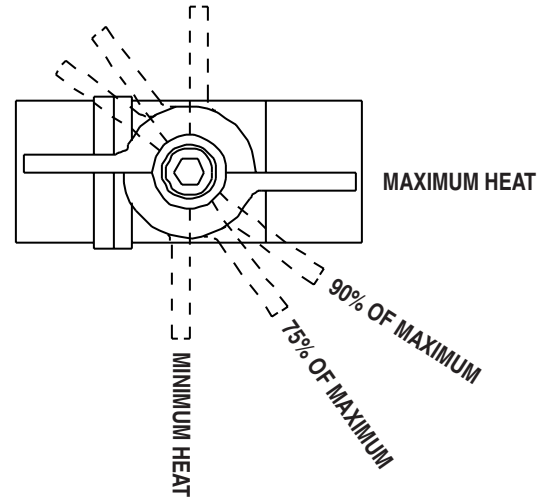

Cleaning Instructions



WARNING

Fire, Burn, and Explosion Hazard

- This heater contains electrical and mechanical components in the gas management, safety and airflow systems.
- Such components may become inoperative or fail due to dust, dirt, wear, aging, or the corrosive atmosphere of an animal confinement building.
- Periodic cleaning and inspection as well as proper maintenance are essential to avoid serious injury or property damage.

1. Before cleaning, shut off all gas supply valves and disconnect electrical supply.
2. The heater should have dirt or dust removed periodically:
 - a. After each flock or between building re-population, give the heater a general cleaning using compressed air or a soft brush on its interior and exterior. At this time, dust off the motor case to prevent the motor from over-heating and shutting the heater down.
 - b. At least once a year, give the heater a thorough cleaning. At this time, remove the fan and motor assembly and brush or blow off the fan wheel, giving attention to the individual fan blades. Additionally, make sure the burner air inlet venturi ports and the “throat” of the casting are free of dust accumulation and the area between the heat chamber top and inside case is also free of dust.
 - c. When washing with water, observe and obey the Warning within these Cleaning Instructions. This same Warning is also supplied on the heater.



WARNING

This heater may be washed only on the external case assembly provided:

- A. The heater is disconnected from the electrical supply.
- B. All access panels are securely closed.
- C. Water spray nozzle shall not discharge within 6 feet of the heater.
- D. The water pressure does not exceed 45 PSIG for 10 seconds on each side of heater.
- E. The heater is not reconnected to electrical supply for a minimum of 1 hour or until the heater is thoroughly dry.

Improper cleaning of the heater can cause severe personal injury or property damage due to water and/or cleaning solution:

1. In electrical components, connections and wires causing electrical shock or component failure.
2. On gas control components causing corrosion which can result in gas leaks and fire or explosion from the leak.

Clean internal components of the heater with a soft, dry brush or cloth, or compressed air.

Maintenance Instructions

1. Have your gas supplier check all gas piping annually for leaks or restrictions in gas lines. Also, at this time have your gas supplier clean out the sediment trap of any debris that may have accumulated.
2. **The appliance area shall be kept clear and free from combustible materials, gasoline, and other flammable vapors and liquids.**
3. Regulators can wear out and function improperly. Have your gas supplier check the date codes on all regulators installed and check delivery pressures to the appliance to make sure that the regulator is reliable.
4. Regulators must be periodically inspected to make sure the regulator vents are not blocked. Debris, insects, insect nests, snow, or ice on a regulator can block vents and cause excess pressure at the appliance.

Service Instructions

MOTOR AND FAN WHEEL ASSEMBLY

1. Shut off the gas supply to the heater.
2. Disconnect the heater from its electrical supply.
3. Open the case fan access panel on the control box end of the heater.
4. Disconnect the motor leads.
5. Remove the screws securing the motor mounting plate to the fan housing.
6. Pull the fan and motor assembly from the housing.
7. Loosen the square head set screw(s) on the fan wheel with a wrench.
8. Pull the fan wheel from the motor shaft. Use a wheel puller if necessary.
9. Remove the four (4) nuts securing the motor to the mounting plate.
10. To replace the motor and fan, reverse the above procedures.

NOTES: a. Fan wheel to motor mount plate spacing must be adjusted to the clearance specified in the table below before tightening the fan wheel to the motor shaft.

b. Make sure that set screw(s) of the fan are on the flats of motor shaft when tightening.

<u>Model</u>	<u>Clearance</u>
AD 250	1/8 - 3/16 in.

FIG. 9

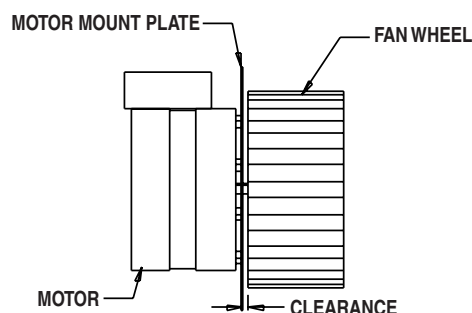

AIR PROVING SWITCH WITH PADDLE

1. Shut off the gas supply to the heater.
2. Disconnect the heater from its electrical supply.
3. Open the case access panel on the control box end of the heater.
4. Remove the two (2) sheet metal screws holding the switch with bracket to blower housing. Remove the assembly by turning the switch assembly 90° so the paddle on the switch arm can be pulled through the oblong hole on side of fan housing.
5. Disconnect the leads from the air proving switch.
6. To replace the switch, reverse the above procedure. The replacement switch will be pre-assembled to its mounting bracket.

FIG. 10

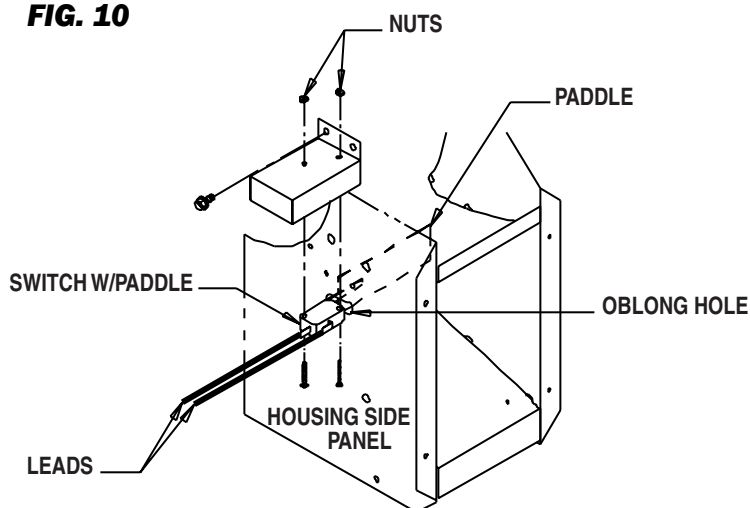

IMPORTANT

Make sure you don't bend the switch arm when installing the replacement switch. Bending the switch arm may create ignition problems later.

TO REMOVE CONTROL BOX AND WIRE HARNESS FROM HEATER

1. Shut off the gas supply to the heater.
2. Disconnect the heater from its electrical supply.
3. Open the motor access panel.
4. Disconnect flame sensor lead and high voltage ignition lead from ignition control and route these back through the rubber grommet in the back of the control box.
5. Trace and disconnect all remaining electrical leads which exit the back of the control box from the components or the areas to which these leads are connected.
6. Remove liquid tight connector nut and sealing washer on inside of control box. Pull connector with leads from back of control box.
7. Remove the three (3) screws on each side of the control panel and remove the control box from the heater.

8. To assemble, reverse above procedure.

FIG. 11

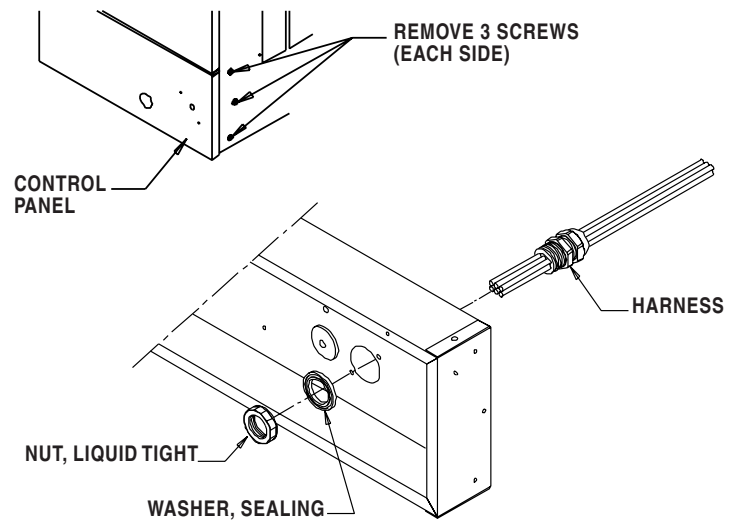

IGNITER AND FLAME SENSOR

1. Close the fuel supply valves to the heater and disconnect the heater from its electrical supply.
2. The igniter and sensor assembly is located within a metal enclosure mounted to the heat chamber above the burner.
3. The igniter/sensor with its enclosure can be removed in its entirety. Remove the screw that secures this assembly to the heat chamber and disconnect the respective leads from the ignition control. Lift the assembly from its mounting slots. See Fig. 13.
4. To reassemble, reverse these procedures.
5. Reconnect the heater to its electrical supply. Open the fuel supply valves to the heater.
6. Start the heater and test for proper operation.

IMPORTANT

- The igniter/sensor assembly may require cleaning due to accumulations of dust and dirt over a period of time, thereby affecting its ability to ignite fuel gas and sense burner flame. Cleaning will require igniter/sensor removal.
 - If spark appears to be weak, briskly rub the igniter electrode with emery cloth or steel wool to remove any buildup. Recycle the heater.
 - If the spark appears strong but the heater cycles off, briskly rub the sensor rod with emery cloth or steel wool to remove any build-up. Recycle the heater.
- Make sure that the igniter gap is 3/16 in. and the igniter tip is positioned over the burner port according to the illustration below. See Fig. 13.

FIG. 12

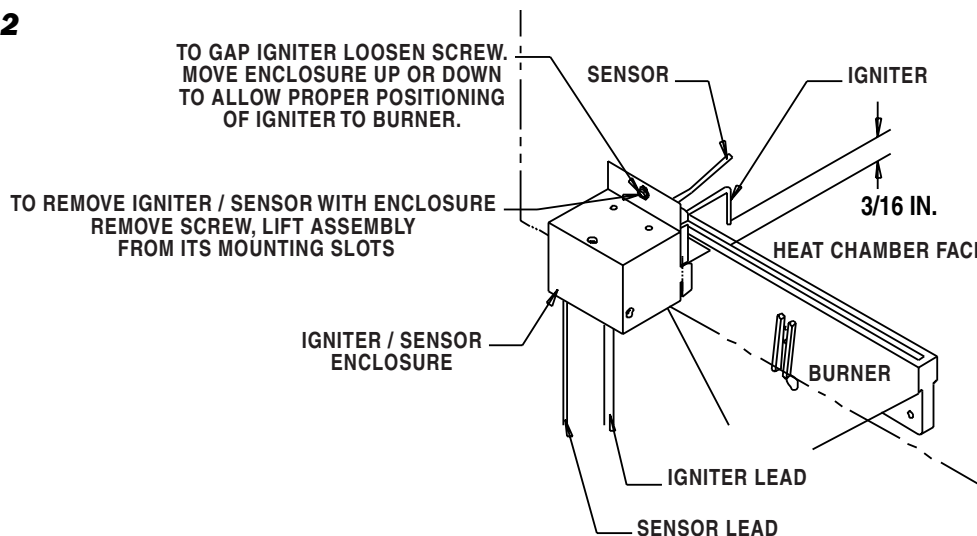

Gas Pressure Checks

WARNING

- Do not disassemble the gas control valve.
- Do not attempt to replace any components of the gas control valve.
- The gas control valve must be replaced if any physical damage occurs to the control valve assembly.
- Failure to follow this warning will result in fire or explosions, leading to injury or death to humans, and property damage.

ATTENTION

- The following explains a typical procedure to be followed in checking gas pressures.
- The gas pressures will vary depending upon fuel type.
- Consult the dataplate on the heater or page 4 in this manual for specific pressures to be used in conjunction with this procedure.
- Gas pressure measured at the inlet to the gas valve is Inlet Pressure and gas pressure measured at the outlet of the gas valve is Burner Manifold Pressure.

A. Preparation

1. Obtain two pressure gauges capable of reading up to 35 in. W.C.
2. Disconnect the heater from the electrical supply and close the fuel supply valve to the heater inlet.
3. Open the burner access panel.
4. Brush or blow off any dust and dirt on or in the vicinity of the gas control valve.

B. Gauge Installation

1. Locate the inlet and outlet pressure taps, see Fig. 14. Remove the pressure tap plug using a 3/16 in. allen key.

FIG. 13

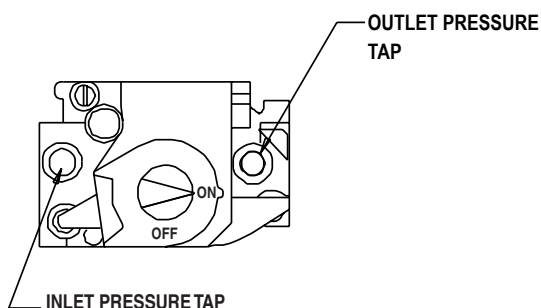
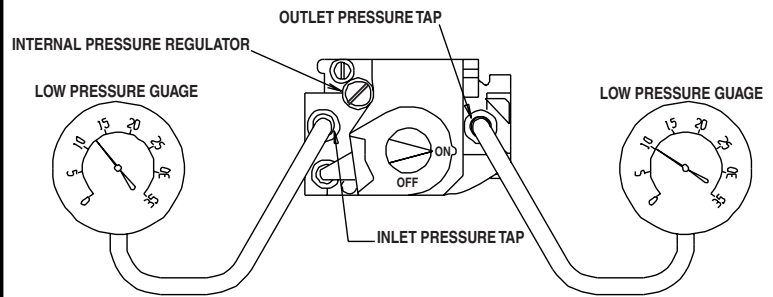

FIG. 14



EXAMPLE SHOWS PRESSURE FOR L.P. GAS ALWAYS REFER TO FUEL TYPE AND PRESSURE ON DATAPLATE

2. Securely connect a pressure gauge to each pressure tap.
3. Open the fuel supply valves to the heater and reconnect the heater electrical supply.
4. Start the heater

C. Reading Pressures

1. With the heater operating, the pressure gauges should read the pressures specified on the dataplate.
2. Do the readings at the inlet and outlet pressure gauges agree with that specified on the dataplate? If so, then no further checking or adjustment is required. Proceed to section D.
3. If the inlet pressures do not agree with that specified on the dataplate, then the regulator controlling gas pressure to the heater requires adjustment.
4. If the inlet pressures are correct and the burner manifold pressure does not agree with that specified on the dataplate, then the gas control valve's internal pressure regulator requires adjustment. See Fig. 15 for regulator location.

D. Completion

1. Once the proper inlet and burner manifold pressures have been confirmed and/or properly set, close the fuel supply valve to the heater and allow the heater to burn off any gas remaining in the gas supply line.
2. Disconnect the heater from its electrical supply.
3. Remove the gauges and connecting hoses.
4. Install pressure tap plugs and tighten securely. Check for gas leaks.

TESTING THE MANUAL RESET HIGH LIMIT SWITCH



WARNING **Fire Hazard**

- Do not operate the heater with the high limit switch bypassed.
- Operating the heater a bypass high limit switch may lead to overheating, possibly resulting in a fire, with subsequent damage to the heater, building damage, or loss of livestock.

The high limit switches should be tested a minimum of once per year when the heater is given a thorough cleaning.

1. Disconnect the heater from its electrical supply.
2. Remove the high limit switch.
3. Holding the switch by one of its mounting legs, apply a small flame only to the sensing portion on the back of the switch. **Be careful not to melt the plastic housing of the switch when conducting this test.**
4. Within a minute, you should hear a pop coming from the switch, which indicates the contacts of the switch have opened. Check for lack of electrical continuity across the switch terminals to verify contacts have opened.

5. Allow the switch cool down for about a minute before firmly pressing the reset button on the switch.
6. Check for electrical continuity across the switch terminals to make sure the contacts have closed.
7. Reinstall the switch back into the heater. Reconnect the heater to its electrical supply. Start the heater and check for proper operation.

FIG. 15

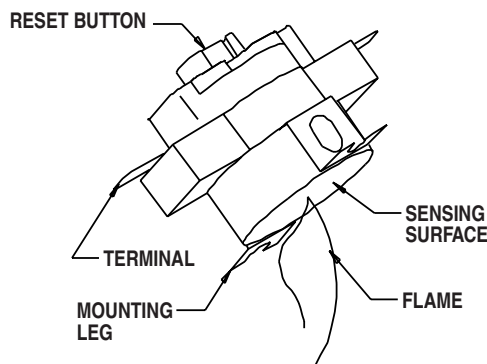

Troubleshooting Instructions

READ THIS ENTIRE SECTION BEFORE BEGINNING TO TROUBLESHOOT PROBLEMS.

 **WARNING**
Electrical Shock and Burn Hazard

- Do not attempt to service or repair this heater unless you are a properly trained and qualified gas heater service person.
- Troubleshooting this system may require operating the unit with line voltage present and gas on. Use extreme caution when working on the heater.
- Failure to follow this warning may result in property damage, personal injury or death.

The troubleshooting flow charts in this section provide systematic procedures for isolating heater problems. Refer to the Component Testing section of this Service Guide for general instructions on performing voltage and continuity checks as well as evaluation of specific components as indicated by these charts. Refer to the appropriate wiring diagram for assistance in performing voltage and continuity checks. Refer to the Service section for gas pressure checks and adjustments as indicated by the flow charts.

TEST EQUIPMENT REQUIRED

The following pieces of test equipment will be required to troubleshoot this system with minimal time and effort.

- **Digital Multimeter** - for measuring voltage and resistance.
- **Low Pressure Gauge** - (L.B. White Part No. 550-00764) for checking inlet and manifold pressures of the gas control valve against dataplate rating.

INITIAL PREPARATION

- Visually inspect heater for apparent damage.
- Check all hoses for abrasion and wear. Replace any that are suspect.
- Make sure heater is properly installed and meets minimum clearances to nearest combustible materials. (Refer to dataplate on heater.)
- Check all wiring for loose connections and worn insulation.

IGNITION AND SAFETY CONTROL

Refer to the system operation sequence in this section to gain an understanding as to how the heater operates. Understanding the operation sequence of the ignition module and related components is essential as it will relate directly to problem solving provided by the flow charts.

The ignition control module is self-diagnostic. The red light on the module will flash a specific pattern depending upon the problem which is diagnosed. To effectively use the flow charts, you must first identify what the problem is by the flashing pattern of the L.E.D. (light emitting diode) diagnostic light. If the light is flashing, the flash pattern will be followed by a pause and then a repeat of the flash pattern until the problem is corrected.

Problems

Page

L.E.D. Diagnostic light <u>not</u> on during a call for heat	20
L.E.D. diagnostic light flashing:	
A. Long Flash	21
B. One Time	21
C. Two Times	22
D. Three Times	23
E. Four Times	24
F. Five Times	24

Components should be replaced only after each step has been completed and replacement is suggested in the flow chart. Refer to the Servicing sections as necessary to obtain information on disassembly and replacement procedures of the component once the problem is identified by the flow chart.

Troubleshooting Instructions

SPARK IGNITION OPERATION SEQUENCE:

- Line Voltage is Sent to Transformer and to Ignition Control
- 24 V.A.C. is sent from Transformer to the Thermostat
- A call for Heat Occurs
- Thermostat Returns 24 VAC to Ignition Control
- Red Light on Ignition Control is Illuminated
- Ignition Control Module Performs an Internal Safe Start Check
 - Internal Components are Tested
 - Voltage is sent to Flame Sensor from Ignition Control to Start Flame Proving Process.
 - Air Proving Switch Circuit Receives 24 Volts from Ignition Control.
- Ignition Control Module Begins Safety Lockout Timing
- Ignition Control Module Starts Fan Motor for Prepurge
 - Air Proving Switch is Checked for Proper Operation.
 - Air Proving Switch closes and 24 Volts is returned to Ignition Control.
- Ignition Control Powers the Igniter and Igniter Sparks.
- Ignition Control Sends 24 Volts to Gas Control through High Limit Switches.
- Ignition Occurs
 - Igniter Continues to Spark until Flame Proving Occurs.
 - Igniter Spark is Discontinued
 - Gas Valve Stays Open
- Room Warms to Desired Temperature
 - Thermostat is Satisfied
 - Heater Shuts Down
- Process Begins Again on Call for Heat

MULTIPLE IGNITION TRIAL SEQUENCE

- First Trial for Ignition Takes Approximately 10 Seconds
- Two More Trials for Ignition will Occur
 - Second and Third Trial Follow Immediately if First Trial Fails
- Module Starts a 15 Minute “Wait” Period to Allow Ignition Interruption to Pass
- Ignition Control Repeats 3 Ignition Attempts After 15 Minute Wait Period
- If Ignition Control Module Does Not Prove Flame After Third Trial, the Module Goes into Safety Lockout (3 Flash Pattern)
 - Igniter Shuts Down
 - Fan Motor Stops
 - Gas Valve Closes
- To Manually Reset the Ignition System
 - Unplug the Heater and Plug it back in
 - OR –
 - On heaters so equipped, turn power supply switch to “Off” and then to “On”
 - OR –
 - Turn Thermostat to “Off” or “No Heat” and Then Back to Above Room Temperature

PROBLEMS

LED constant on → Normal operation.

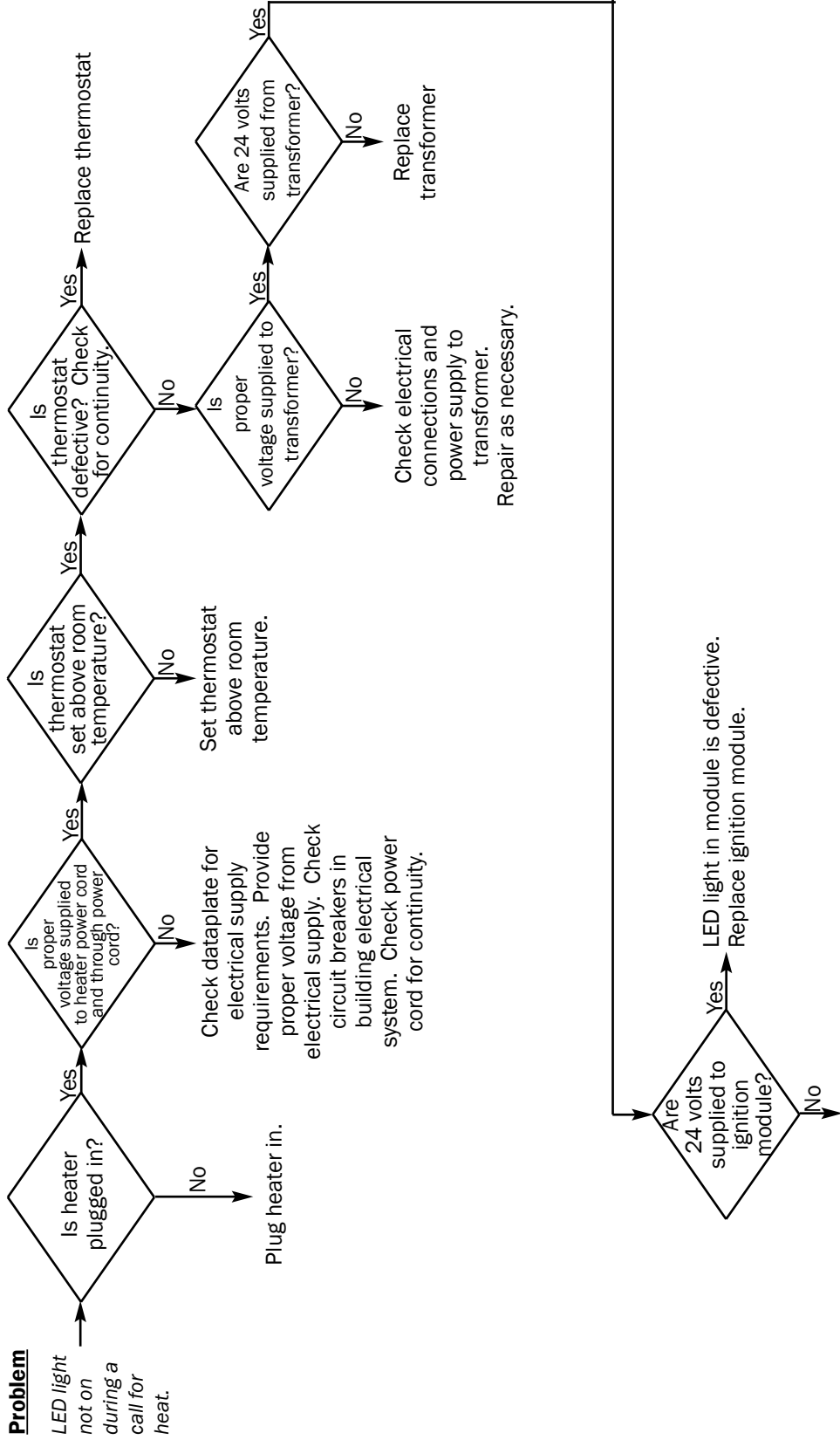

Problem**LED Flashing**

Long Flash → Heater has attempted two ignition trials. Heater is in a 15 minute wait period before attempting its third (final) trial for ignition. If ignition is not achieved after the third trial, the heater will lock out and the ignition control module will present the three time flash pattern. Either recycle the heater or wait for heater to attempt third ignition trial.

Two seconds on, two seconds off repetitively for 15 minutes.

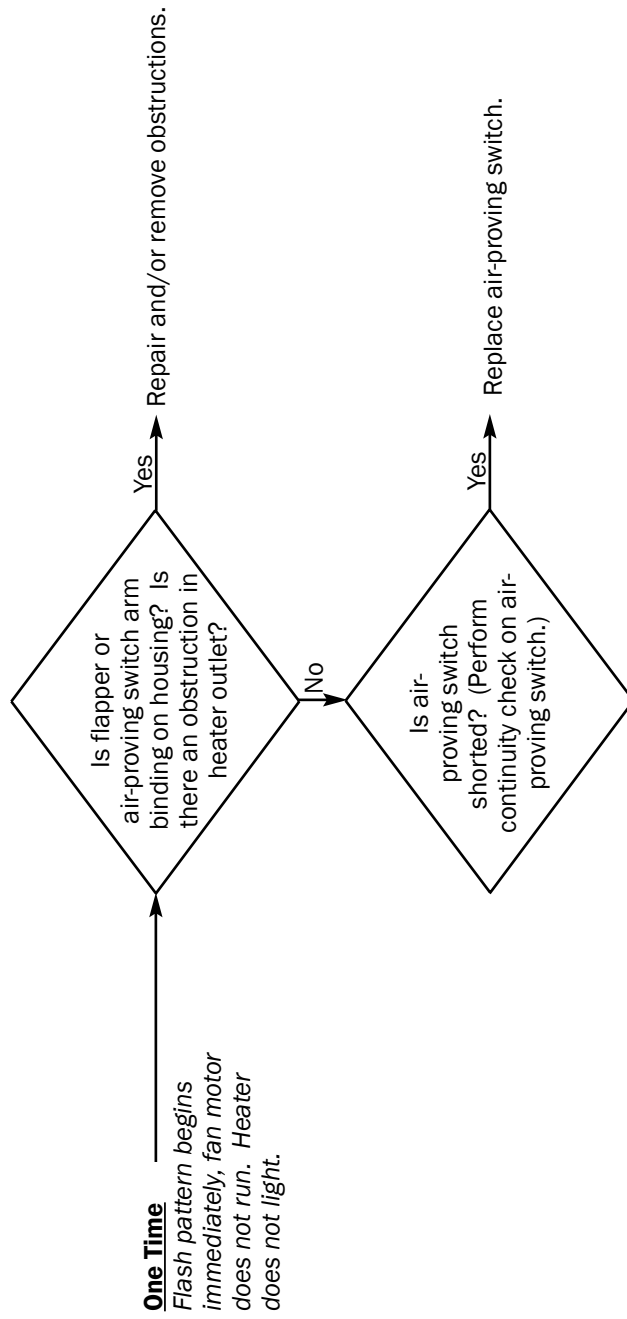

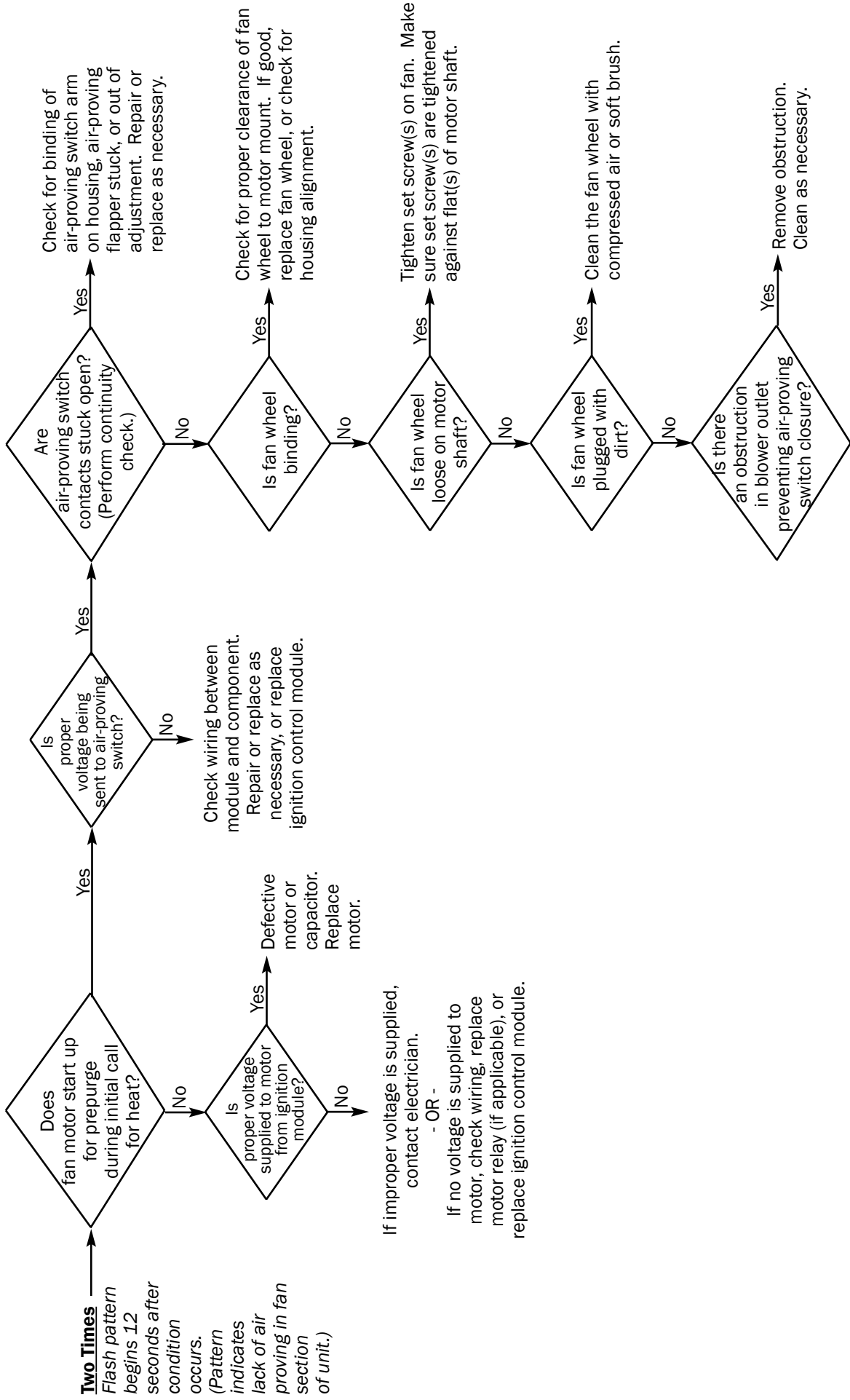

Three Times
Lack of
ignition.
The module
has gone into
safety lockout.

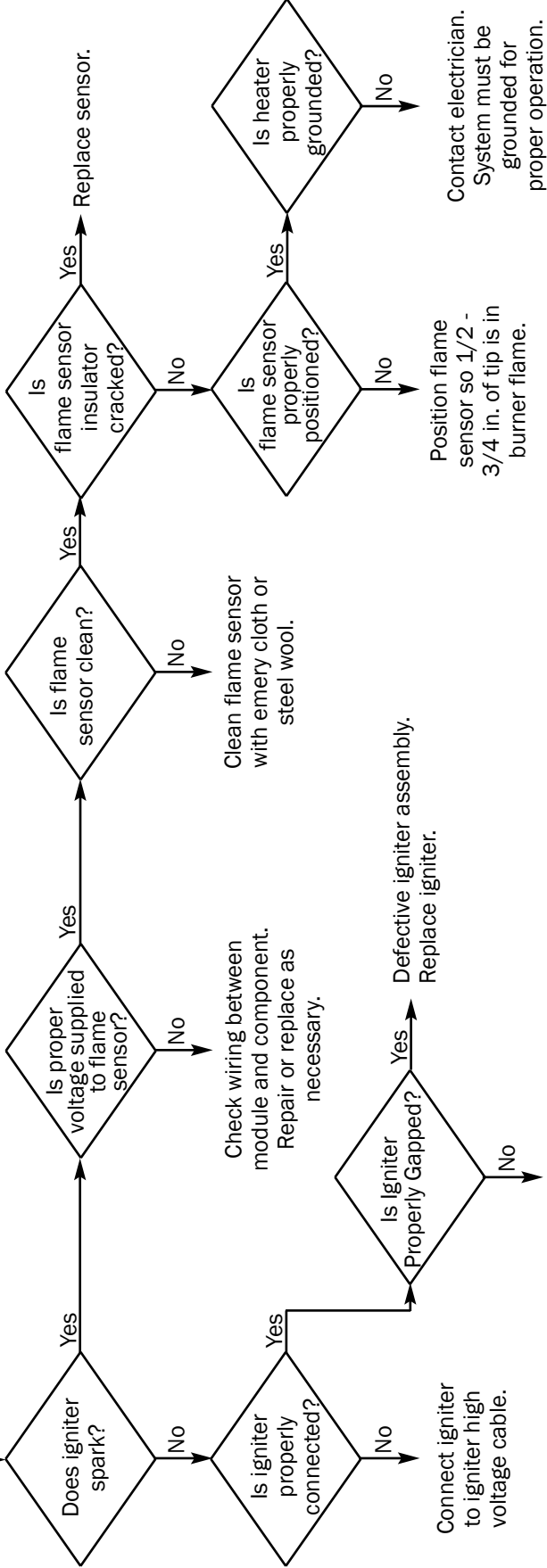
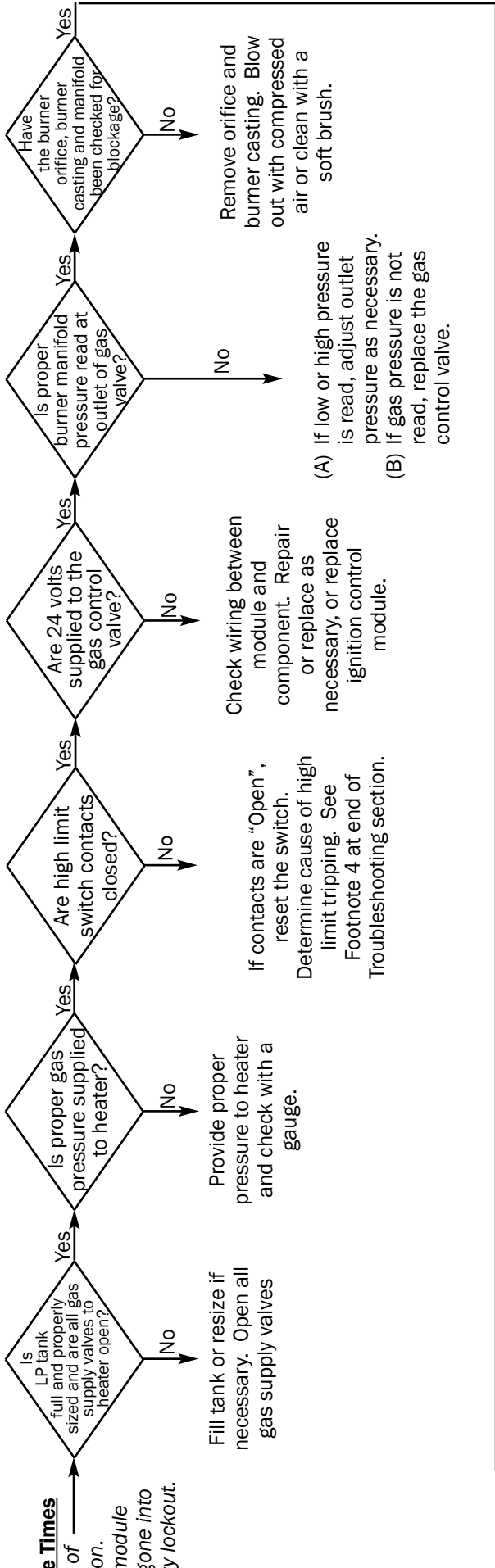

Four Times → Flame Sense Degradation. See flame sensor related problems in three time flash pattern.

Five Times → If DSI board does not reset, then replace the board. (Internal board fault.)
Rapid On/Off cycling of the burner.
If DSI board resets, then have qualified electrician check power source for power quality problems. (Frequency, line noise, line spikes, loose connections, too small wire gauge.)

- (1) With any electrical problem, all wiring should be checked for good connections and proper voltage and repaired if a problem is found.
- (2) **IMPORTANT:** Remember, the ignition control board sends and receives voltages throughout the entire operation sequence. The ignition control board terminals should also be checked for delivering proper voltages, in addition to the individual components as indicated by the respective flash pattern, to make sure the board itself is working properly.
- (3) In order to verify the diagnosis of the flashing LED or to reset the unit and retry ignition, disconnect the unit from power and then reconnect to power or if your heater uses a thermostat, turn down thermostat below room temperature and then turn thermostat above room temperature. When testing is completed, reset thermostat to desired temperature.
- (4) The high-limit switch will open or “trip” for a variety of reasons, such as high gas pressure, low voltage, excessive dust and dirt build-up within the heater, dirty fan assembly, fan is not tightened onto motor shaft, and obstructions in air inlets or discharge outlet of heater.

Electrical Connection and Ladder Diagram

CAUTION

Always refer to the heater's electrical connection diagram when servicing to avoid wiring errors and heater malfunction. Check for proper operation after servicing.

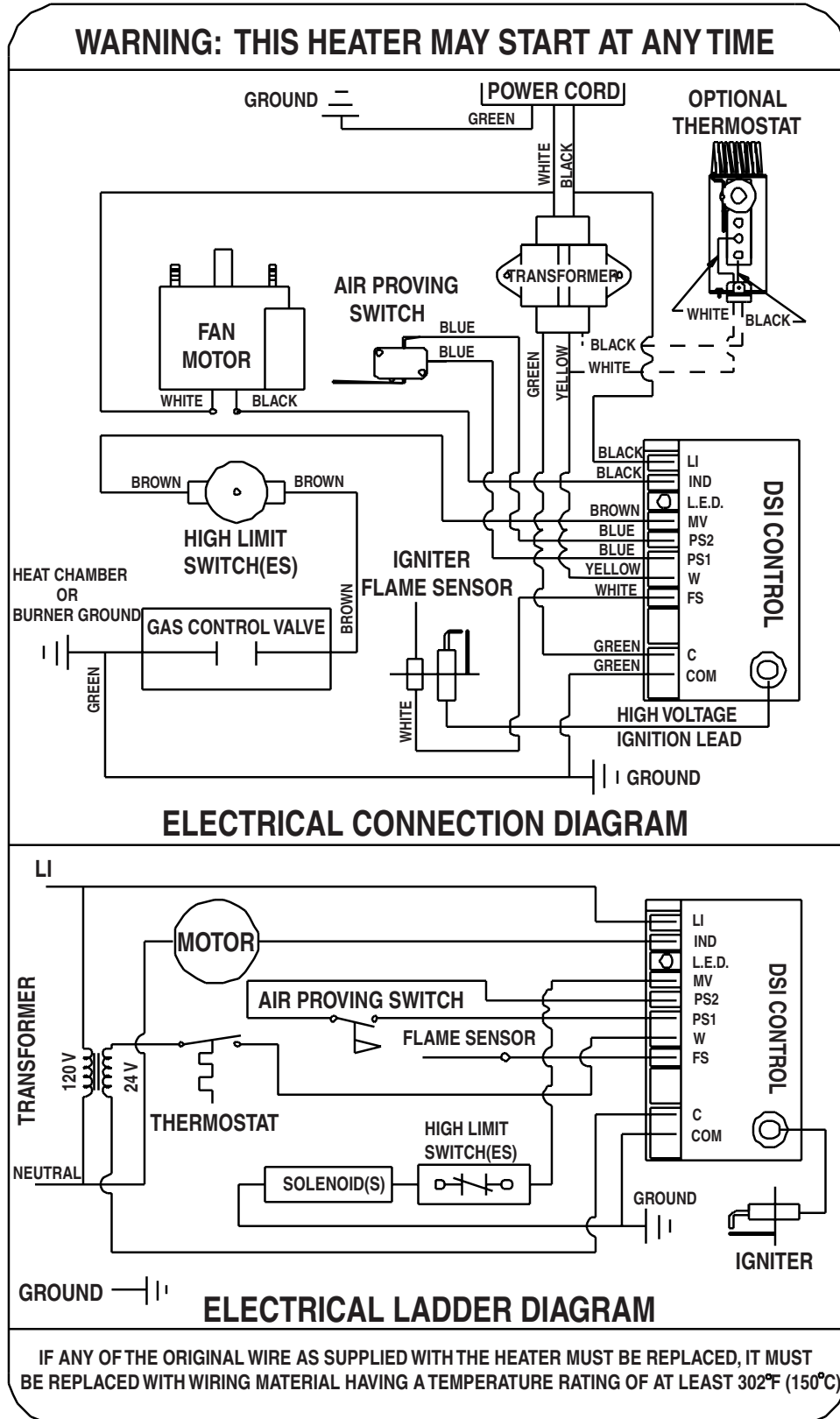

Heater Component Function

Air Proving Switch

Safety device used to insure that the proper air flow is being achieved before the gas valve is opened.

Burner

Cast iron component used to channel gas and provide an area at which the fuel may ignite.

Burner Orifice

Brass metering device used to feed gas to burner at a specific rate.

Fan Housing

Chamber used for compressing air for efficient air movement.

Fan Wheel

Component used in conjunction with the motor and fan housing to pull the hot air from heater and blow it into room for heating (also known as a “squirrel cage”).

Gas Control Valve

A device which consists of a low pressure regulator and electrical solenoids which are used for the control of gas flow to the burner assembly. A feature of the control is a built in gas shut off which is used to isolate the heater from its gas supply when servicing.

Gas Hose

Flexible connector used to convey gas from supply line in building to heater.

Heat Chamber

Metal “fire box” within the appliance that provides an area where burner flame mixes with combustion air thereby providing heat.

High Limit Switch

Safety device wired into the control system which is used to break an electrical circuit to the gas control valve in event of overheat situation.

Ignition Control Module

Controls the ignition sequence and operation of the heater as well as monitoring the safety services. A major service feature is the board’s ability to diagnose component and flame failure by means of a diagnostic light located within the module. This light will provide a specific flash pattern repetitively, depending on the type of component failure that has occurred.

Igniter/Flame Sensor Assembly

This assembly consists of two components mounted adjacent on the same bracket.

- Spark Igniter: Electrical ignition device used on automatic ignition control systems. Ignites gas by a spark.
- Flame Sensor: Also known as a flame rod or flame probe, this device works in conjunction with the ignition module in proving that burner flame has been established.

Motor

Electric device used to force preheated air through the heater and to circulate heat within a certain area. Converts electrical energy into mechanical energy.

Regulator

The heart of any gas supply installation. Used to deliver a working pressure to the appliance under varying conditions in tank pressure.

Thermostat

Electrical device used as an automatic “on/off” switch which will respond to changes in temperature in a certain area. Can be wired so contacts in the thermostat open or close on temperature increase or decrease.

Throttle Valve

Manually adjustable component used to increase or decrease the flow of gas to the burner. The throttle valve is located between the gas control valve and burner assembly.

Transformer

This device is responsible for reducing a higher incoming voltage (normally 120 V.A.C.) to a lower outgoing voltage. The lower voltage (24 V.A.C.) is essential to operate the ignition control module.

Parts Identification

PARTS SCHEMATIC

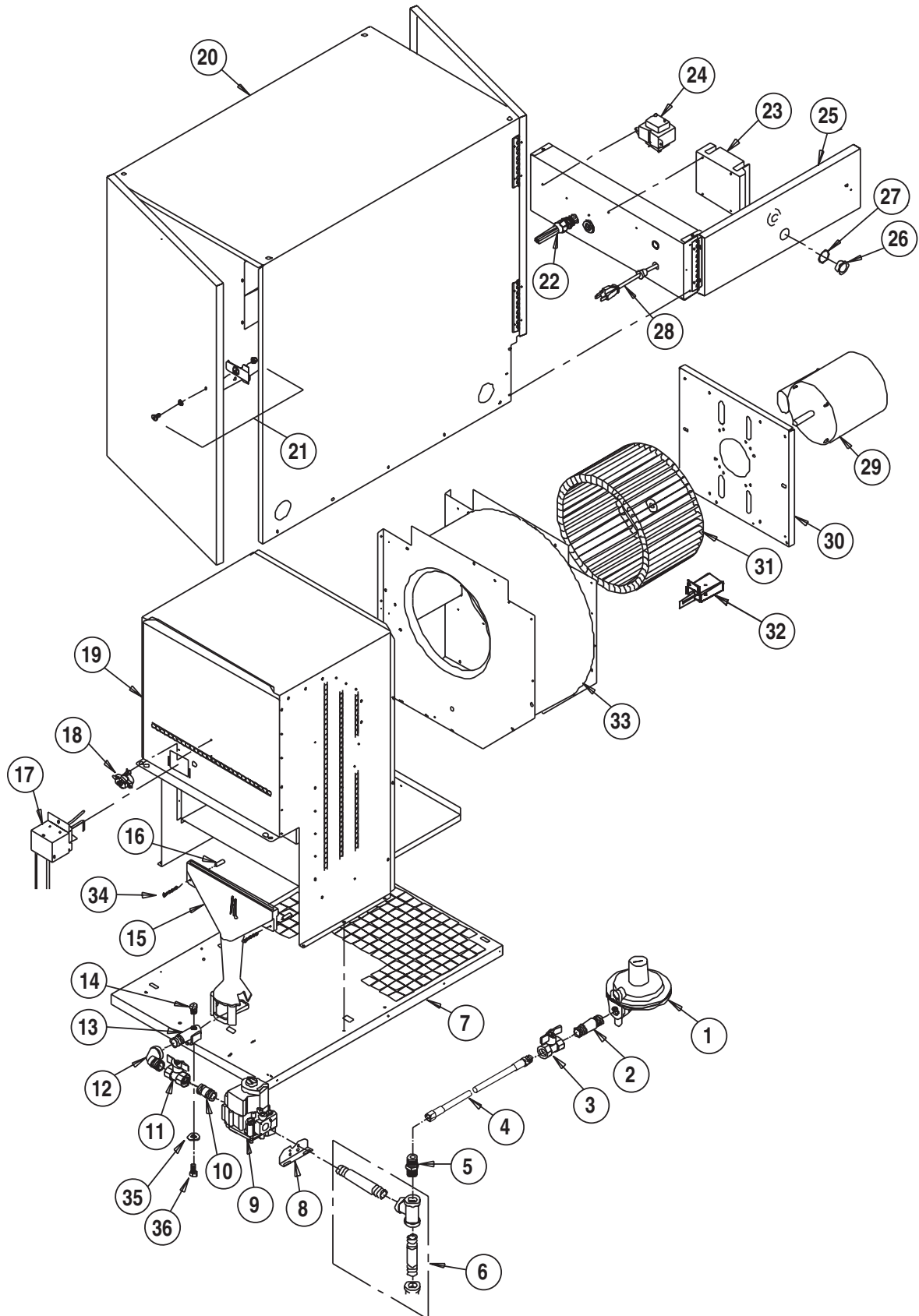

Parts Identification

PARTS LIST

Item	Description	Part Number
1	Regulator, LP Gas, 2nd Stage, Vent Over Outlet	06553
	Regulator, LP Gas, 2nd Stage, Vent Over Side	06665
	Regulator, Natural Gas (5 PSIG Inlet, 13.5 Outlet)	07087
2	Nipple, 3 1/2 in.	07148
3	Valve, Manual Shut Off	05548
4	Hose, 1/2 in. ID x 10 ft. with Adapter	20714
5	Adapter, Hose, 1/2 NPT x 1/2 NPS	02894
6	Kit, Sediment Trap	00815
7	Base	20136
8	Bracket, Gas Control Valve	21768
9	Valve, Gas Control: LP Gas	22076
	Valve, Gas Control: Natural Gas	22078
10	Nipple, 1/2 in. x 1 1/2 in.	02420
11	Valve, Throttle: LP Gas	20143
	Valve, Throttle: Natural Gas	20144
12	Ell, Street	01359
13	Manifold	09291
14	Orifice, Burner: LP Gas	20141
	Orifice, Burner: Natural Gas	20142
15	Burner	21781
16	Spacer	02687
17	Igniter and Sensor Assembly	22473
18	Switch, High Limit	05566
19	Chamber, Heat	21734
20	Case, Assembly with Doors and Latches	22458
21	Latch Assembly	20959
22	Harness, 6 wire	22842
23	Control, Ignition	24900
24	Transformer, 120/24 v.	09615
25	Cover, Control Box	22465
26	Plug, Window	08255
27	O-Ring	08347
28	Cord, Power, 10 ft.	20133
29	Motor, 1/3 HP, Ball Bearing	20169
30	Mount, Motor	08647
31	Wheel, Fan	09050
32	Air Flow Switch Assembly	24157
33	Housing, Fan, with Air Flow Switch Assembly and Motor Mount	24167
34	Screw, Burner	02688
35	Washer	01589
36	Bolt	02692

(1) Complete control box assembly, specify galvanized - Part #24235 or painted - Part #24236 and country use.

(2) For fixed rate heater, replace items 11, 12 and 13 with a 1/2 in. elbow, part #130-01426 and a nipple, 1/2 in. x 3 1/2 in., part #130-07148.

(3) Specify model number and fuel type when ordering.

Warranty Policy

HEATER

L.B. White Co., Inc. warrants that the component parts of its heater are free from defects in material and workmanship, when properly installed, operated, and maintained in accordance with the Installation and Maintenance Instructions, safety guides and labels contained with each unit. If, **within 12 months from the date of purchase by the end user**, any component is found to be defective, L.B. White Co., Inc. will at its option, repair or replace the defective part or heater, with a new part or heater, F.O.B., Onalaska, Wisconsin.

A warranty card on file at L.B. White will automatically qualify a unit and its component parts for warranty consideration. If a warranty card is not on file, a copy of the bill of sale will be required to establish warranty qualification. If neither is available, the warranty period will be 12 months from date of shipment from L. B. White.

PARTS

L.B. White Co., Inc. warrants that replacement parts purchased from the company and used on the appropriate L. B. White equipment are free from defects both in material and workmanship for **12 months from the date of purchase by the end user**. Warranty is automatic if a component is found defective within 12 months of the date code marked on the part. If the defect occurs more than 12 months later than the date code but within 12 months from the date of purchase by the end user, a copy of a bill of sale will be required to establish warranty qualification.

duration to the duration of the applicable warranty stated above. The remedies set forth above are the sole and exclusive remedies available hereunder. L.B. White will not be liable for any incidental or consequential damages directly or indirectly related to the sale, handling or use of the equipment, and in any event L.B. White's liability in connection with the equipment, including for claims based on negligence or strict liability, is limited to the purchase price.

The warranty set forth above is the exclusive warranty provided by L.B. White, and all other warranties, including any implied warranties or merchantability or fitness for a particular purpose, are expressly disclaimed. In the event any implied warranty is not hereby effectively disclaimed due to operation of law, such implied warranty is limited in

Some states do not allow limitations on how long an implied warranty lasts, so the above limitation may not apply to you. Some states do not allow the exclusion or limitation of incidental or consequential damages, so the above limitation or exclusion may not apply to you. This warranty gives you specific legal rights, and you may also have other rights which vary from state to state.

Replacement Parts and Service

Contact your local L.B. White dealer for replacement parts and service or call the L.B. White Co., Inc. at 1-800-345-7200 for assistance. Be sure that you have your heater model number and configuration number when calling.